

# IOWA STATE UNIVERSITY

**Department of Chemical and Biological Engineering**

## **Undergraduate Student Booklet**

**2014-2015 Catalog  
Revised May 2014**

**[che-advising@iastate.edu](mailto:che-advising@iastate.edu)**

**<http://www.cbe.iastate.edu/current-students/guides-and-handbooks>**

## Chemical and Biological Engineering Faculty

NAME	TITLE	OFFICE	PHONE	E-MAIL
M. Akinc	Professor (Courtesy)	2220C Hoover	4-0738	makinc@iastate.edu
K. M. Bratlie	Asst. Professor	2220Q Hoover	4-7297	kbratlie@iastate.edu
R. C. Brown	Dist. Professor	1140E BRL	4-7934	rcbrown@iastate.edu
G. Burnet	Dist. Professor Emeritus		4-7642	gxb@iastate.edu
L. Cademartiri	Asst. Professor (Courtesy)	2220 Hoover	4-4549	lcademar@iastate.edu
R. Cademartiri	Adjunct Asst. Professor	1031 Sweeney	4-3327	rcademar@iastate.edu
E. W. Cochran	Assoc. Professor	1035 Sweeney	4-0625	ecochran@iastate.edu
L. Dong	Assoc. Professor (Courtesy)	2115 Coover	4-0388	ldong@iastate.edu
R. O. Fox	Dist. Professor	3162B Sweeney	4-9104	rofox@iastate.edu
C. E. Glatz	University Professor	2149 Sweeney	4-8472	cglatz@iastate.edu
K. R. Hebert	Professor	3133 Sweeney	4-6763	krhebert@iastate.edu
T. J. Heindel	Professor (Courtesy)	2018 Black Engr	4-0057	theindel@iastate.edu
J. M. Heinen	Senior Lecturer	3033 Sweeney	4-1891	jodonnll@iastate.edu
J. C. Hill	University Professor	3155 Sweeney	4-4959	jchill@iastate.edu
A. C. Hillier	Professor and Chair	2114 Sweeney	4-3678	hillier@iastate.edu
L. R. Jarboe	Assoc. Professor	3051 Sweeney	4-2319	ljarboe@iastate.edu
D. D. Johnson	Professor (Courtesy)	311 TASF	4-9649	ddj@ameslab.gov
K. R. Jolls	Professor Emeritus	2155 Sweeney	4-5222	jolls@iastate.edu
M. H. Lamm	Assoc. Professor	1037 Sweeney	4-6533	mhlamm@iastate.edu
W. Li	Assoc. Professor	2140 BRL		
S. D. Loveland	Senior Lecturer	2052 Sweeney	4-3024	prairie@iastate.edu
S. K. Mallapragada	Professor	2031 Sweeney	4-7407	suryakm@iastate.edu
B. Narasimhan	Professor	2035 Sweeney	4-8019	nbalaji@iastate.edu
M. Olsen	Assoc. Professor (Courtesy)	3025 Black	4-0073	mgolsen@iastate.edu
M. Panthani	Asst. Professor			
A. Passalacqua	Asst. Professor (Courtesy)	2074 Black Engr	4-5047	albertop@iastate.edu
P. J. Reilly	Dist. Professor Emeritus		4-7642	reilly@iastate.edu
D. K. Rollins	Professor	1033 Sweeney	4-5516	drollins@iastate.edu
R. C. Seagrave	Dist. Professor Emeritus		4-7642	seagrave@iastate.edu
I. C. Schneider	Asst. Professor	3053 Sweeney	4-0450	ians@iastate.edu
B. H. Shanks	Professor	1140L BRL	4-1895	bshanks@iastate.edu
J. V. Shanks	Professor	3031 Sweeney	4-4828	jshanks@iastate.edu
Z. Shao	Asst. Professor	4140 BRL	4-1132	zyshao@iastate.edu
C. K. Stiehl	Senior Lecturer	3063 Sweeney	4-5825	cstiehl@iastate.edu
J.-P. Tessonier	Asst. Professor	2138 BRL	4-4595	tesso@iastate.edu
R. D. Vigil	Assoc. Professor	3037 Sweeney	4-6438	vigil@iastate.edu
Q. Wang	Adjunct Asst. Professor	352 Town Engr	4-4218	qunwang@iastate.edu
T. D. Wheelock	Univ. Professor Emeritus	3157 Sweeney	4-5226	wheel@iastate.edu
Y. Wu	Assoc. Professor			

### Support Staff

Jenny Gibbs	Academic Adviser	2162C Sweeney	4-2127	jjibbs@iastate.edu
Shannon Grundmeier	Academic Adviser	2162D Sweeney	4-5927	shannong@iastate.edu
Bellinda Hegelheimer	Program Assistant	2162A Sweeney	4-1660	bellinda@iastate.edu
Brenda Kutz	Academic Adviser	2162B Sweeney	4-3960	bkutz@iastate.edu
Bette Maybee	Admin Specialist	2114 Sweeney	4-7642	bjmaybee@iastate.edu
DeAnn Pitman	Secretary	2162 Sweeney	4-7643	dpitman@iastate.edu
Don Schlagel	Systems Support Specialist	1144 Sweeney	4-4919	schlage@iastate.edu
Molly Seaboch	Program Assistant	2117 Sweeney	4-7870	mseaboch@iastate.edu

# TABLE OF CONTENTS

Important Deadlines & Dates 2014-2015	v
Introduction	vi
<b>Part 1: General Information</b>	<b>1</b>
The Profession of Chemical Engineering	2
Chemical & Biological Engineering Facilities	2
Department Administration	2
Undergraduate Student Lounge	2
Small Group Meeting Rooms	2
Computation Laboratories	2
Release of Student Information	3
Advising	3
Academic Integrity	4
American Institute of Chemical Engineers (AIChE) Code of Ethics	4
Tornado/Severe Weather Guidelines	5
<b>Part 2: Curriculum &amp; Requirements</b>	<b>6</b>
Outcomes of the Program	7
Basic Program Requirements	7
Core Course Requirement	8
Design Experience	8
Social Science and Humanities (SSH) Electives	8
Undergraduate Degree Planning	13
Undergraduate Curriculum in Chemical Engineering	17
Undergraduate Curriculum in Chemical Engineering - Biological Engineering Option	19
Electives	21
Biological Engineering Option	22
Suggested Emphases for Technical Electives	22
General Graduate School Preparation	22
General Industrial Preparation	23
Biochemical Engineering	23
Biomedical Engineering	23
Environmental Science and Engineering	23
Food Engineering	24
Materials Science	24
Bioengineering Minor	25
Policies	26
Transfer Credits	26
English Proficiency Requirement	26
Diversity/International Perspectives	26
Graduation Requirements	26
Pass-Not Pass Policy	26

# TABLE OF CONTENTS

<b>Part 3: Opportunities for Undergraduates</b>	<b>27</b>
International Studies in Chemical and Biological Engineering	28
International Summer Study Program	28
International University Exchanges	28
National University of Singapore	29
Monterrey Tec	29
University College London – Chemical and Biochemical Engineering	29
University of Limerick, Ireland	29
Swiss Federal Institute of Technology — Lausanne	30
Bogaziçi University (BU) and Middle East Technical University (METU) — Turkey	30
Other International Opportunities	30
Honors Program	31
Undergraduate Research Program and Independent Study	31
Faculty and Their Research Interests	32
American Institute of Chemical Engineers (AIChE)	34
National Organization of Black Chemists and Chemical Engineers (NOBCChE)	34
Omega Chi Epsilon	35
Other Honor Societies	35
Employment and Scholarship Opportunities	35
Loans	36
Part-Time Employment	36
Research Helpers	36
Student Assistants	36
Cooperative (Work-School) Program	36
Internships	37
Process for Relevant Work Experiences	37
<b>Part 4: Preparing for the Future</b>	<b>38</b>
Permanent Employment	39
Graduate Study in Chemical and Biological Engineering	39
Preparation for Non-Engineering Graduate Study	40
Medical School	40
Business School (MBA)	40
Law School	40

## Important Deadlines and Dates 2014-2015

	<u>Fall 2014</u>	<u>Spring 2015</u>
Classes Start (contact the instructor if you miss first day)	8/25/14	1/12/15
Undergraduate graduation applications in AccessPlus due	5/31	12/19
Fee Payment Due		
First Payment (minimum due) or payment in full	8/20	1/20
Second Payment (minimum due)	9/20	2/20
Final Payment	10/20	3/20
University holiday, offices closed, classes not in session	9/1	1/19
Second half-semester courses begin	10/20	3/9
Registration Begins (for the next term) (Make an appointment to see your advisor)	10/23	3/24
Schedule Changes (Forms in 2162 Sweeney)		
Last day through AccessPlus	8/29	1/16
Last day without fee	8/29	1/16
Last day to drop without appearing on permanent record or counting toward total course drop limits	8/29	1/16
Last day to change a course from audit to credit	8/29	1/16
Last day to change from Pass-Not Pass to grade basis without counting toward total Pass-Not Pass allowance	9/8	1/26
Last day to elect to audit a course – instructor must approve	9/8	1/26
Last day to add/drop without extenuating circumstances	10/31	3/27
Last day to indicate a non-automatic designated repeat	10/31	3/27
Last day to change to or from Pass/Not Pass basis. Course will count toward the total P/NP credits allowed.	10/31	3/27
Break	11/24-11/28	3/16-3/20
Final Exams (schedule on web from beginning of semester) <a href="http://www.registrar.iastate.edu/exams/">http://www.registrar.iastate.edu/exams/</a>	12/15-12/19	5/4-5/8

# Introduction

This booklet has been prepared to help you plan your program in chemical engineering at Iowa State University and is intended to guide you through the chemical engineering curriculum, to describe various opportunities and options, and to relay important policies and procedures. Other information sources are:

- ❖ Academic Departments at ISU  
<http://www.iastate.edu/depts>
- ❖ College of Engineering  
<http://www.engineering.iastate.edu>
- ❖ Course Equivalency Guide  
<http://www.admissions.iastate.edu/equiv/index.php>
- ❖ Department of Chemical and Biological Engineering  
<http://www.cbe.iastate.edu>
- ❖ Experimental (###X) Course Descriptions  
<http://www.registrar.iastate.edu/faculty-staff/courses/explisting>
- ❖ General Catalog (curriculum and course information)  
<http://catalog.iastate.edu>
- ❖ *Iowa State Daily* (student newspaper)  
<http://www.iowastatedaily.com>
- ❖ ISU Information Handbook (academic regulations)  
<http://policy.iastate.edu>
- ❖ ISU Academic Calendar  
<http://www.registrar.iastate.edu/calendar>
- ❖ ISU Academic Information Technologies  
<http://www.it.iastate.edu>
- ❖ ISU Registrar Forms  
<http://www.registrar.iastate.edu/forms>
- ❖ Pre-Health Information  
<http://www.las.iastate.edu/pre-health>
- ❖ Pre-Law Information  
<http://www.las.iastate.edu/pre-law>
- ❖ Schedule of Classes  
<http://classes.iastate.edu>
- ❖ Scholarship Information  
<http://www.financialaid.iastate.edu>  
<http://www.engineering.iastate.edu/student-services/scholarships>  
<http://www.fastweb.com>  
<http://federalstudentaid.ed.gov>  
<http://www.finaid.org>
- ❖ Student Answer Center  
<http://financialaid.iastate.edu/sac>
- ❖ Student Organizations  
<http://sodb.stuorg.iastate.edu>
- ❖ Tuition and Fees  
<http://www.registrar.iastate.edu/fees>
- ❖ Weather  
<http://www.ehs.iastate.edu/prep/weather>
- ❖ Writing Center  
<http://new.dso.iastate.edu/wmc>

More information can also be found at:

- ❖ The undergraduate bulletin board at the east entrance of Sweeney Hall
- ❖ The Mike and Jean Steffenson Student Services Center in Room 2162 Sweeney Hall

# **Part 1: General Information**

## The Profession of Chemical Engineering

Chemical engineering is an exciting and diverse profession with a tremendous range of occupations and opportunities. Chemical engineers have always been proud of their flexibility. A solid and very general technical background enables them to work effectively in and adapt quickly to many different fields.

The chemical engineer is an expert at dealing with the chemical and physical changes of matter and with the conversion of energy. Most chemical engineers use this knowledge in jobs that involve the application of chemical research to the production of chemical materials and products. This entails product development and market research; economic feasibility studies; research; development and design of chemical processes; design of process equipment; supervision of the construction, start-up, operation, and maintenance of chemical plants; and process improvement for pollution control and energy conservation.

Chemical engineers are found working in such diverse areas as business, applied physics, manufacturing, applied mathematics, biochemistry, medicine, patent law, food processing, pollution monitoring and prediction, sales, and industrial management. All of these are in addition to the already wide range of types of jobs traditionally thought of as chemical engineering jobs.

Chemical engineers are employed in a wide variety of industries: petroleum and gas, chemicals, minerals and metals; glass and ceramics; plastics and resins; soap and detergents; cosmetics; rubber and tire; food production; fertilizer and agricultural chemicals; nuclear energy; photographic products; microchip manufacturing; missile and space; synthetic fibers and textiles; paint, paper, and cellulose; pharmaceuticals; and process equipment manufacture. They also are involved in private consulting, government and higher education.



## Chemical and Biological Engineering Facilities

Sweeney Hall houses classrooms, a reading room, computer laboratories, research and teaching laboratories, and departmental and staff offices.

### Department Administration

The department office and the office of the Department Chair are located in 2114 Sweeney Hall. The department office telephone number is 515-294-7642. The Mike and Jean Steffenson Student Services Center is located in 2162 Sweeney Hall; the telephone number is 515-294-7643.

### Undergraduate Student Lounge

You have a place to study or just hang out in 0107 Sweeney. Comfortable seating, tables with chairs, a phone, and several computers are available in this room. The code to unlock the door can be requested from the staff in 2162 Sweeney Hall.

### Small Group Meeting Rooms

A room (1153 Sweeney Hall) is open for undergraduate students to use for studying or working on projects. No reservations are necessary. If you want to ensure that the room will be available at a particular time, just hang a note on the door beforehand. Additionally, 3149 Sweeney Hall is a laptop computer lab that is available when not in use by a class.

### Computation Laboratories

The Department of Chemical and Biological Engineering has a growing list of computer resources available to undergraduate students. The department has two main laboratories devoted to undergraduate student use.



Rooms 1123 and 1150 Sweeney Hall are open to all chemical engineering students. These rooms are reserved for classes several hours during the week. Other labs across campus also offer computers for general use.

**INSTALLATION OF PERSONAL SOFTWARE IS PROHIBITED ON THESE MACHINES**

Visit <http://it.eng.iastate.edu/> to obtain an account and to request support for computer and printing problems. This web page also contains descriptions of the hardware and software available in every College of Engineering computer lab.

**Support:** Don Schlagel ([schlage@iastate.edu](mailto:schlage@iastate.edu)) is the systems support specialist for the department. His office is located in 1144 Sweeney Hall. If he is unavailable, you can request help from the college computer support at [marstontech@iastate.edu](mailto:marstontech@iastate.edu).

## Release of Student Information

The department routinely receives requests from employers and graduate schools to provide names of potential candidates to aid them in their recruitment. We will provide such lists, with directory information, unless you request that we not include you in such releases. We do not release individual GPA information unless the student has authorized the organization to request it. You may request exclusion by submitting a written request to DeAnn Pitman in 2162 Sweeney Hall, or set your information release preferences in AccessPlus.

## Advising

The primary point of contact for most advising questions will be your academic adviser. The academic advising staff will help you with the class registration process, degree audit corrections, answering questions about ISU, College of Engineering, and departmental policies and procedures, handling class scheduling difficulties, and guiding you to campus resources. You also will visit your academic adviser each semester for guidance regarding class registration and to receive your current Registration Access Number (RAN). See the ISU Academic calendar for registration advising dates. Shortly after enrolling in CH E 202, you will also be assigned to a faculty mentor. At this time, you will also receive a Plan of Study (POS) form (page 14), which you should attempt to complete before meeting with your faculty mentor. Visit with your faculty mentor to discuss progress and goals, select electives that support your program of study, generate career goals, learn more about the profession of chemical engineering, gain assistance in applying to graduate school, and for any other issue that requires faculty expertise.

You are expected to plan your Program of Study (POS) and choose courses to meet the elective requirements for a more intentional college experience. Degree Audits (DA) show your progress toward completing degree requirements and are available in AccessPlus at any time to you or your academic adviser.

If you are on Academic Warning or Probation based upon the grades you earned in the fall or spring semester, you must complete an Academic Intervention Self-Assessment as soon as possible (available on AccessPlus). Once this is complete, you must meet with your academic adviser to discuss the obstacles that have impacted your academic success no later than the 10<sup>th</sup> class day of the subsequent semester.

**Your faculty mentor is the primary source for:**

- Developing an elective package
- Information about the profession
- Career and profession questions
- Working on a degree program
- Discussing undergraduate independent study projects
- Obtaining a recommendation letter
- Learning about graduate school

**The ChE Academic Advising Staff can help with:**

- How to add or drop a course, or register
- Consulting on course adds/drops
- Information about degree requirements
- Resolving course scheduling problems
- Signing co-op and internship forms
- Providing copies of forms you need or department publications
- Guidance to campus and community resources

## Academic Integrity

It is imperative that society be able to rely upon the integrity of the members of our profession. At the university, faculty members expect you to follow high ethical standards in your academic work. Rules and procedures regarding actions that constitute academic dishonesty are included in the Iowa State University Information Handbook. These apply to all students. In addition, the chemical engineering faculty have adopted the following policy statement, which applies in chemical engineering courses.

Faculty members expect that work submitted in your name be entirely your own work. You should not copy assignments, exams, quizzes, computer programs, etc. from others or allow copying of your work. It is usually permissible to discuss homework assignments with other students, unless your instructor specifies to the contrary. For examinations and quizzes, a stricter standard is imposed. For exams and quizzes the presumption, unless otherwise stated, is no discussion, no use of notes, no use of books or journals, and no use of work of others. If in a particular instance the instructor wishes to modify any part of the department policy, you will be so informed in writing.

### American Institute of Chemical Engineers (AIChE) Code of Ethics

Members of the American Institute of Chemical Engineers shall uphold and advance the integrity, honor, and dignity of the engineering profession by: being honest and impartial and serving with fidelity their employers, their clients, and the public; striving to increase the competence and prestige of the engineering profession; and using their knowledge and skill for the enhancement of human welfare. To achieve these goals, members shall:

- ❖ Hold paramount the safety, health and welfare of the public and protect the environment in performance of their professional duties
- ❖ Formally advise their employers or clients (and consider further disclosure, if warranted) if they perceive that a consequence of their duties will adversely affect the present or future health or safety of their colleagues or the public
- ❖ Accept responsibility for their actions, seek and heed critical review of their work and offer objective criticism of the work of others
- ❖ Issue statements or present information only in an objective and truthful manner.
- ❖ Act in professional matters for each employer or client as faithful agents or trustees, avoiding conflicts of interest and never breaching confidentiality
- ❖ Treat fairly and respectfully all colleagues and co-workers, recognizing their unique contributions and capabilities
- ❖ Perform professional services only in areas of their competence
- ❖ Build their professional reputations on the merits of their services
- ❖ Continue their professional development throughout their careers, and provide opportunities for the professional development of those under their supervision
- ❖ Never tolerate harassment
- ❖ Conduct themselves in a fair, honorable, and respectful manner

## Tornado/Severe Weather Guidelines

If your area is threatened by a tornado, your primary thought should be how to save lives, not possessions. Time is of the essence. You may only have time to duck under a sturdy table or get into an interior hallway.

**DO NOT** activate the fire alarm!

- ✦ Seek safe places for shelter, such as steel-reinforced office buildings, storm shelters, tunnels, sub-basements, underground parking facilities, basements, and interior corridors.
- ✦ Keep away from windows, structures with large free-span roofs such as auditoriums and gymnasiums, the upper stories of multi-story buildings, house trailers and parked cars.
- ✦ An automobile, whether parked or moving, is the most dangerous place to be. Violent winds can tumble a car over and over, crushing it and its occupants. Seek shelter immediately. Do not attempt to drive out of the storm path, because this has proven fatal to many motorists. If you are trapped in open country, seeking shelter in a ravine or ditch may be your only hope. However, be aware of the torrential rains that often accompany tornadic weather.
- ✦ If you are in an office building, dormitory, or any other multi-story structure, go to interior hallways on a lower floor, preferably in the basement. In homes, a basement usually offers the greatest safety. If no basement is available, take cover under heavy furniture in the center of the house against strong inside walls. Covering yourself with a rug or blanket provides some protection against flying glass and falling debris. If you are in a mobile home park, or any non-reinforced structure without a basement, seek shelter elsewhere, such as a public building, friend's basement, community shelter, etc. At shopping centers, stay away from large glass windows. If possible, take cover under a strong counter.
- ✦ No matter where you are, do some advance planning. Identify protective areas you can get to in a hurry.
- ✦ Take responsibility for receiving your own severe weather notifications — sign up for an e-mail or text alert from your local TV station's website.

### Severe Weather Definitions

<b>Tornado Watch</b>	Conditions are favorable for tornadoes (or severe thunderstorms) to occur. Stay informed.
<b>Tornado Warning</b>	A tornado or severe thunderstorm is occurring or is imminent. Seek shelter immediately.
<b>Severe Thunderstorm</b>	A storm that produces wind damage, dime-size hail or larger and winds up to 58 mph.
<b>Tornado</b>	A violently rotating column of air in contact with the ground and coming from a thunderstorm.
<b>Funnel cloud</b>	Similar to a tornado, but not in contact with the ground.

**NOTE:** At Iowa State, all the permanent brick and stone buildings on central campus are of reinforced construction and offer good shelter. Remember to stay away from outside windows and doors and go to interior hallways and basements if possible. If you live in university housing, be sure to review the information and instructions that the Department of Residence-Housing has provided on tornado safety routines. Find this information online at <http://www.housing.iastate.edu/life/safety/weather>.

## **Part 2: Curriculum and Requirements**

## Outcomes of the Program

The chemical engineering program should produce graduates that have:

- ◆ An ability to apply knowledge of mathematics, science and engineering
- ◆ An ability to design and conduct experiments as well as to analyze and interpret data
- ◆ An ability to design a chemical engineering system, component or process to meet desired needs
- ◆ An ability to function on multi-disciplinary teams
- ◆ An ability to identify, formulate, and solve chemical engineering problems
- ◆ An understanding of professional and ethical responsibility
- ◆ The ability to communicate effectively
- ◆ The broad education necessary to understand the impact of chemical engineering solutions in a global and societal context
- ◆ Recognition of the need for and an ability to engage in lifelong learning
- ◆ A knowledge of contemporary issues
- ◆ The ability to use the techniques, skills and modern engineering tools necessary for engineering practice
- ◆ Demonstrated thorough grounding in chemistry and a working knowledge of advanced chemistry such as organic, inorganic, physical, analytical, materials chemistry, or biochemistry
- ◆ A working knowledge, including safety and environmental aspects, of material and energy balances applied to chemical processes; thermodynamics of physical and chemical equilibria; heat, mass and momentum transfer; chemical reaction engineering; continuous and stage-wise separation operations; process dynamics and control; process design; and appropriate modern experimental and computing techniques
- ◆ An ability to function as engineers in an international setting
- ◆ An ability to function as professional engineers in the industries related to chemical engineering
- ◆ An ability to pursue research and advanced studies in chemical engineering or in related fields such as medicine, law, and business

**Course descriptions may be found in the current ISU Catalog, which is available online at <http://catalog.iastate.edu/azcourses/>.**

## Basic Program Requirements

Engineering students are required to complete certain basic courses as a condition of enrollment in engineering courses at the 200-level or above. The general requirement is to complete the engineering Basic Program with a grade point average of 2.00 or better (transfer credits are included in this average). The basic program courses are:

MATH 165, MATH 166  
ENGL 150, ENGL 250  
ENGR 101, CH E 160

CHEM 177 (or CHEM 167)  
PHYS 221  
LIB 160

Students are to complete the basic program prior to enrolling in 200-level engineering courses; however, ENGL 150 and ENGL 250 may be taken concurrently. These and other exceptions are listed under the College of Engineering Curricula in the ISU Catalog (<http://catalog.iastate.edu/collegeofengineering>).

For transfer students, enrollment is permitted for no more than two semesters prior to satisfying the basic program requirements. For transfer students, certain waivers and substitutions are possible and should be discussed with your academic advisor as early as possible. It is allowable to:

1. Substitute transfer credit for ChE 160 only if the coursework contains both engineering problem-solving and computer programming experience.
2. Substitute CHEM 167 for CHEM 177.
3. English Placement info: <http://www.agstudent.iastate.edu/orientation/english%20placement%20info.htm>.

## Core Course Requirement

The College of Engineering requires that each student must have a minimum GPA of 2.00 in a group of 200-level and above courses to meet graduation requirements. The chemical engineering faculty have designated the following chemical engineering courses as core courses for this requirement: CH E 202, CH E 210, CH E 310, CH E 325, CH E 356, CH E 357, CH E 358, CH E 381, CH E 382, CH E 420, CH E 421, CH E 426, and CH E 430. The Degree Audit available in AccessPlus will show this grade point average each semester under Chemical Engineering Core. Transfer credits will be included in this average. The cumulative GPA is based upon all courses, excluding transfer courses. This means the grade point average will be based upon those courses that were actually taken at Iowa State University.

## Design Experience

The design experience begins in the second year in CH E 210, Materials and Energy Balances, in which students are introduced to the design and computation tools that will be used in subsequent courses. Introduction to databases, data manipulation and reduction, and the use of numerical method packages are covered, along with the concept of optimization and economic design. The design experience then continues through the sequence of primarily engineering science courses — fluid mechanics, heat transfer, mass transfer, thermodynamics, reaction engineering and process control. At least one organized design experience is in each of these courses.

Meanwhile, a significant emphasis on the design process is in each of the chemical engineering laboratory courses. Students will design at least one new experiment in each of these courses. The senior elective courses include a design experience. Finally, the capstone design course, CH E 430, brings together all of these elements in an integrated design experience.

The overall plan is to distribute the process of learning to design chemical engineering processes, products and systems throughout the curriculum in a continuous experience.

## Social Science and Humanities (SSH) Electives

Both Iowa State University and industry want our graduates to be well-rounded professionals who can interact with their coworkers, business clients, and society. Social Science and Humanities (SSH) electives are an important part of your chemical engineering degree program. These courses can help you develop or expand skills necessary to achieve success within both industry and society.

A similar Iowa State University and CBE department goal is to prepare you to meet the challenges of responsible citizenship and effective professional roles in a culturally diverse global community. To help achieve this goal, all undergraduate students must fulfill graduation requirements in two areas: U.S. Diversity (USDiv) and International Perspectives (IP). The focus of the U.S. Diversity requirement is the multicultural society of the United States. Courses used to meet the requirement provide students with insights that enhance their understanding of diversity among people in the U.S. The focus of the International Perspectives requirement is the global community. Its objective is to promote your understanding of cultural diversity and interdependence on a global scale. Many of the courses on the following SSH list fulfill both SSH and either USDiv or IP requirements. If the chosen US Diversity or International Perspective course is not on the SSH list, additional SSH credits must be taken to meet the minimum 15 SSH credits.

SSH requirements include:

- Minimum of 15 credits from the list of approved courses below
- At least 6, but no more than 9, credits must be in the same department

The following list of approved SSH's have notations if they also meet the US Diversity or the International Perspectives requirement. **Refer to the online list for a more complete listing of US Diversity and International Perspectives (<http://www.registrar.iastate.edu/courses/div-ip-guide.html>).** *Note that some departments offer courses where most are acceptable for SSH requirements. For these departments, the list of courses in this handbook include only those courses that also meet US Diversity or International Perspectives requirements, but other courses from this department may apply to the SSH requirements.*

The International Perspectives requirement may be alternatively met with an academic experience involving a stay in a foreign country of three weeks or greater duration. A course involving travel abroad for less than three weeks is also approved for use in meeting the requirement if it carries three or more academic credits. International students are exempt from completing a course to fulfill the International Perspectives requirement; however, the requirement of completing a minimum of 15 credits from the SSH list still must be met.

Applying Independent Study (490) courses for the Social Science and Humanities Electives will require **prior** approval by your advisor and Curriculum Committee. Consult with your advisor for courses not on this list, such as Honors Seminars, experimental courses, or other courses that you think might qualify.

The following list of SSH courses is extensive. To help you determine which courses to take a helpful strategy is to start with topics (departments) that are of interest to you. Use the course catalog to look up the descriptions of the first few courses in these departments, since those are most likely to have no or few prerequisites. For example, if you are interested in psychology, look at the descriptions for PSYCH 101, 230, and 280 to decide which course to include in your course schedule. After taking one or two of these courses, you may want to review upper-level course descriptions for any additional courses of interest to you.

You may use the Schedule of Classes website under the Students tab on ISU's homepage (<http://classes.iastate.edu/>) to help you to decide on a course any particular term. For example, if you wanted to fulfill the USDiv requirement during the Fall 2014 semester, first select the Fall 2014 term at the top. Under the Advanced Search, select U.S. Diversity Requirement and submit. The resulting list of courses may all be used to meet the USDiv requirement and includes information about scheduling, prerequisites, credits, instructors, and availability. A description of each course is available by clicking on the underlined course number.

Dept	Course #	US Div	Int'l Persp
<b>A M D</b>			
	165	X	
	257		
	354		X
	356		
	362		X
	372		X
	467		
<b>Acct (Accounting)</b>			
	215		
<b>AESHM</b>			
	342	X	
	379	X	
	421		X
<b>Af Am</b>			
All courses except 490			
	201	X	
	330	X	
	334	X	
	347	X	
	350	X	
	353	X	
	354	X	
	460	X	
<b>Agron</b>			
	342		X
	450		
<b>Am In</b>			
All courses except 490			
	210	X	
	240	X	
	310	X	
	315	X	
	320	X	
	322	X	
	323		X
	328	X	
	342	X	
	346	X	
	426	X	
<b>Anthr</b>			
	201		X
	202		
	220		X
	230		X
	306		X
	307		
	308		
	309		X
	313		X
	315	X	
	320	X	
	321		
	322	X	
	323		X
	332	X	
	336		X
	340		X
	411		X

Dept	Course #	US Div	Int'l Persp
<b>Anthr cont.</b>			
	418		X
	444		X
	450		
<b>Arch</b>			
	221		X
	222		X
	271		
	321	X	
	420	X	
	422		X
	423		X
	424		
	425		
	426	X	
	427		X
<b>ArtGr</b>			
	388	X	
<b>Art H</b>			
All courses except 490			
	280		X
	281		X
	292	X	
	382		X
	384		X
	395	X	
	481		X
	494	X	
<b>Biol</b>			
	173		
	307	X	
<b>Ch E</b>			
	391		X
<b>CI St</b>			
All courses except 480 & 490			
	273		X
	275		X
	353		X
	372		X
	373		X
	374		X
	376		X
	394		X
<b>Com Dis</b>			
	286	X	
<b>ComSt</b>			
	310		X
	323	X	

Dept	Course #	US Div	Int'l Persp
<b>C R P</b>			
	270	X	
	291		X
	293		
	376		
	417		
	484		
	491		
<b>CJ St</b>			
	240		
	241		
	320		
	332		
	340		
	341		
	351		
	352		
	402		
	403		
<b>Dance</b>			
	270		
	360		
<b>Dsn S</b>			
	181		
	183		
	221		X
	222		X
	274	X	
	280		X
	281		X
	291		X
	292	X	
	293		
	321	X	
	371		
	373		X
	382		X
	383		
	385		
	395	X	
	396		
	417		
	481		X
	484		
	487		
	489		
	491		
	494	X	
<b>Econ</b>			
	101		
	102		
	301		
	302		
	312		
	320		
	321	X	
	344		

Dept	Course #	US Div	Int'l Persp
<b>Econ cont.</b>			
	353		
	355		X
	362		
	370		X
	376		
	378	X	
	380		
	385		X
	455		X
	480		
<b>Engr</b>			
	320		X
	327		
<b>Engl</b>			
	201		
	219		
	225		
	226		
	227		
	228		
	237		
	240	X	
	260		
	275		
	330		
<b>335 - 396 inclusive</b>			
	340	X	
	344	X	
	345	X	
	346	X	
	347	X	
	349	X	
	352	X	
	353		X
	354		X
	370		X
	374		X
	375		X
	376		X
	389		X
	420		
	422	X	
	440		
	441		
	445		
	450		
	460		



Dept	Course #	US Div	Int'l Persp
<b>Env S</b>			
	160		
	173		
	201		
	220		X
	293		
	320		
	334		
	342		X
	345		X
	355		
	380		
	382		
	383		
	384		X
	442		
	450		X
	460		
	472		
	484		
	491		
<b>FS HN</b>			
	342		X
<b>Geron</b>			
	373		
	377	X	
	378	X	
<b>Hist</b>			
All courses except 490 & 495			
	201		X
	202		X
	207		X
	240	X	
	280		X
	281		X
	284		X
	323		X
	336		X
	337		X
	338		X
	339		X
	341		X
	353	X	
	354	X	
	374		X
	380	X	
	383		X
	386	X	
	389		X
	390		X
	421		X
	422		X

Dept	Course #	US Div	Int'l Persp
<b>Hist cont.</b>			
	473	X	
<b>HD FS</b>			
	102		
	227		
	239	X	
	240	X	
	249	X	
	270		
	276	X	
	367		
	373		
	377	X	
	378	X	
	479		
<b>H Sci</b>			
	150	X	
<b>Int St</b>			
	235		X
	430		X
<b>JI MC</b>			
	101		
	401		
	460		
	461		
	462		
	464		
	474		X
	476		X
	477	X	
<b>L A</b>			
	272	X	
	274	X	
	371		
	373		X
<b>LAS</b>			
	211	X	
	322	X	
	325	X	
	328X	X	
	385		X

Dept	Course #	US Div	Int'l Persp
<b>Ling</b>			
	119		X
	219		
	286	X	
	305		
	309		X
	413		
	420		
	422	X	
	463		X
<b>Mgmt</b>			
	370		
	371		
	414		
	419		
	471		
	472	X	
<b>Mat E</b>			
	220		X
	391	X	
<b>M E</b>			
	220		X
	484		X
<b>Music</b>			
	102		X
	302		
	304	X	
	383		X
	384		X
	472	X	
	473		
	475		
	476		
<b>Phil</b>			
All courses except 207 & 490			
	235	X	
	338	X	
<b>Pol S</b>			
All courses except 301,475, & 490			
	241		X
	251		X
	315		X
	333	X	
	347		X
	349		X
	350		X
	354		X
	385	X	
	452		X

Dept	Course #	US Div	Int'l Persp
<b>Psych</b>			
	101		
	230		
	280		
	313		
	314		
	346	X	
	347	X	
	348		
	360		
	380		
	381		
	383		
	401		
	413		
	450		
	460		
	484		
	488		X
<b>Relig</b>			
All courses except 490 & 499			
	205		X
	210	X	
	242		X
	323		X
	328	X	
	333		X
	334	X	
	336	X	
	340		X
	342	X	
	352		X
	355		X
	356		X
	358		X
	376		X
	384		X
	453		X
<b>Soc</b>			
All courses beyond 130 except 202, 302, 412, 460, 464, & 490			
	220		X
	235	X	
	327	X	
	328	X	
	330	X	
	331	X	
	332	X	
	345		X
	411		X
<b>Sp Cm</b>			
	212		
	305		
	312		
	323	X	
	350		
	417		

Dept	Course #	US Div	Int'l Persp
<b>T SC</b>			
	220		X
	341		
	342		X

343		
474		X
<b>Thtre</b>		
110		
465		
466		
<b>U St</b>		
321	X	
<b>W S</b>		
All courses except 258, 490, 491, & 499		
160	X	
201	X	
203	X	
205	X	
222	X	
301		X
302	X	
307	X	
321	X	
323	X	
327	X	
328	X	
333	X	
336	X	
338	X	
340	X	
342	X	
345	X	
346	X	
350	X	
352	X	
370		X
374		X
380	X	
385	X	
386	X	
422	X	
444		
494	X	

Dept	Course #	US Div	Int'l Persp
<b>W L C</b>			
All WLC courses except 490 & 499 for all curricula. NOTE: Students may not use grammar, conversational, or composition courses in the native language.			
WLC 119			X
WLC 270			X
WLC 484			X
<b>Arabc</b>			
102			X
201			X
<b>Chin</b>			
102			X
201			X
202			X
301			X
302			X
304			X
320			X
370			X
378			X
<b>Czech</b>			
102			X
201			X
202			X
<b>Frnch</b>			
102			X
201			X
202			X
301			X
304			X
320			X
333^			X
334^			X
370			X
375^			X
378			X
395			X

Dept	Course #	US Div	Int'l Persp
<b>Ger</b>			
102			X
201			X
202			X
301			X
302			X
304			X
305			X
320			X
330			X
370			X
371			X
375			X
378			X
395			X
476			X
<b>Greek</b>			
102			X
201			X
332			X
<b>Latin</b>			
102			X
201			X
332			X

Dept	Course #	US Div	Int'l Persp
<b>Rus</b>			
102			X
201			X
202			X
301			X
304			X
314			X
370			X
375			X
378			X
395			X
<b>Span</b>			
102			X
195			X
201			X
202			X
295			X
301			X
303			X
304			X
314			X
321			X
322			X
323			X
324			X
326			X
330			X
331			X
332			X
333			X
351			X
352			X
354			X
370			X
395			X
440			X
401			X
441			X
445			X
463			X

## Undergraduate Degree Planning

The purpose of planning your chemical engineering degree is to allow you to determine what courses/programs/activities will help you meet your goals in a timely manner.

On the flowchart that follows, cross off courses that you already have completed and circle the courses in which you are currently enrolled. Complete the Plan of Study (POS) form on the next page by following the steps below:

1. Completely fill out the heading.
2. List credits that can be used to meet degree requirements that were earned before entering ISU (transfer, AP, test out, etc.) in the first semester block. Label this semester as "TR" for transfer.
3. List any transfer course that needed to be evaluated in the "Approved Course Substitutions" with the ISU course number that it was evaluated as being "equivalent to" or as a "substitute for."
4. The next Semester block would be your first term at ISU. Label it appropriately (e.g., "F14" for Fall 2014; "S15" for Spring 2015; or either "SS15" or "1'15" for Summer 2015). List all courses taken that term. Do this for each term through the current term.
5. Continue listing courses that you plan to take for future terms, checking off each course on your flowchart as you list it on the POS form. This will help you to account for each requirement without listing the requirement more than once.
6. List each elective course on the right column under the requirement that it will meet. Do this as you list the course in the term that you will take the course.
7. Keep in mind/make sure:
  - A. Courses are available during the term that you have scheduled them
  - B. Credit loads for each semester are within acceptable limits ( $\leq 18$  credits per semester, or  $\leq 21$  for Honors Program)
  - C. All course prerequisites are satisfied
  - D. All curriculum requirements for graduation are satisfied.
8. Discuss your POS with your faculty mentor. Changes made to the Technical Elective choices are to be approved by your faculty mentor.

# CHEMICAL ENGINEERING CURRICULUM PLAN of Study (2014-15 Catalog)

Name \_\_\_\_\_ ID# \_\_\_\_\_ Entry Term \_\_\_\_\_ GRAD TERM \_\_\_\_\_ Date \_\_\_\_\_

Honors  Bio-Option  Double Degree w/ \_\_\_\_\_ Double Major w/ \_\_\_\_\_ Minor in \_\_\_\_\_

Start with *applicable* transfer courses, fill in the courses prior to ISU, have taken, currently taking, and plan to take.  
 Label terms as TR (transfer, AP, CLEP); F10; S11; 1'11 (summer), etc.  
 Make sure: 1. Courses are available in the term that you schedule them (e.g., ChE 392 is summer-only).  
 2. All course prerequisites and all curriculum requirements for graduation are satisfied.

## ELECTIVES

### SSH

INT'L PERSPECTIVE (3 CR)

\_\_\_\_\_ Cr  
 \_\_\_\_\_ Cr

US DIVERSITY (3 CR)

\_\_\_\_\_ Cr  
 \_\_\_\_\_ Cr

SINGLE DEPT. (6-9 CR)

\_\_\_\_\_ Cr  
 \_\_\_\_\_ Cr  
 \_\_\_\_\_ Cr

OTHER SSH COURSES

\_\_\_\_\_ Cr  
 \_\_\_\_\_ Cr  
 \_\_\_\_\_ Cr  
 Total \_\_\_\_\_ (15 Cr)

### TECHNICAL

COMMUNICATION

\_\_\_\_\_ Cr  
 Total \_\_\_\_\_ (3 Cr)

ADVANCED CHEMISTRY

\_\_\_\_\_ Cr  
 \_\_\_\_\_ Cr  
 \_\_\_\_\_ Cr  
 Total \_\_\_\_\_ (3 Cr)

STATISTICS

\_\_\_\_\_ Cr  
 Total \_\_\_\_\_ (3 Cr)

CHEMICAL ENGINEERING

\_\_\_\_\_ Cr  
 \_\_\_\_\_ Cr  
 Total \_\_\_\_\_ (6 Cr)

ENGINEERING

\_\_\_\_\_ Cr  
 \_\_\_\_\_ Cr  
 Total \_\_\_\_\_ (3 Cr)

PROFESSIONAL

\_\_\_\_\_ Cr  
 \_\_\_\_\_ Cr  
 \_\_\_\_\_ Cr  
 Total \_\_\_\_\_ (3 Cr)

APPROVED COURSE SUBSTITUTIONS					
	for _____	_____ for _____	_____ for _____	_____ for _____	
SEMESTER _____	CR _____	SEMESTER _____	CR _____	SEMESTER _____	CR _____
_____	_____	_____	_____	_____	_____
_____	_____	_____	_____	_____	_____
_____	_____	_____	_____	_____	_____
_____	_____	_____	_____	_____	_____
_____	_____	_____	_____	_____	_____
Total		Total		Total	
SEMESTER _____	CR _____	SEMESTER _____	CR _____	SEMESTER _____	CR _____
_____	_____	_____	_____	_____	_____
_____	_____	_____	_____	_____	_____
_____	_____	_____	_____	_____	_____
_____	_____	_____	_____	_____	_____
_____	_____	_____	_____	_____	_____
Total		Total		Total	
SEMESTER _____	CR _____	SEMESTER _____	CR _____	SEMESTER _____	CR _____
_____	_____	_____	_____	_____	_____
_____	_____	_____	_____	_____	_____
_____	_____	_____	_____	_____	_____
_____	_____	_____	_____	_____	_____
_____	_____	_____	_____	_____	_____
Total		Total		Total	
SEMESTER _____	CR _____	SEMESTER _____	CR _____	SEMESTER _____	CR _____
_____	_____	_____	_____	_____	_____
_____	_____	_____	_____	_____	_____
_____	_____	_____	_____	_____	_____
_____	_____	_____	_____	_____	_____
_____	_____	_____	_____	_____	_____
Total		Total		Total	
SEMESTER _____	CR _____	SEMESTER _____	CR _____	SEMESTER _____	CR _____
_____	_____	_____	_____	_____	_____
_____	_____	_____	_____	_____	_____
_____	_____	_____	_____	_____	_____
_____	_____	_____	_____	_____	_____
_____	_____	_____	_____	_____	_____
Total		Total		Total	

ChE 392 is the 4-cr. Unit Ops lab that subs for ChE325/426 held each June in Oviedo, Spain

ADVISOR NOTES/STUDENT OBJECTIVE:

Signature \_\_\_\_\_

Print Name \_\_\_\_\_

Faculty Mentor

# CHEMICAL ENGINEERING FLOWCHART, 2014-15 CATALOG (129 CREDITS)

Term/Year

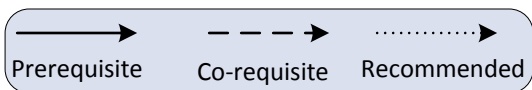
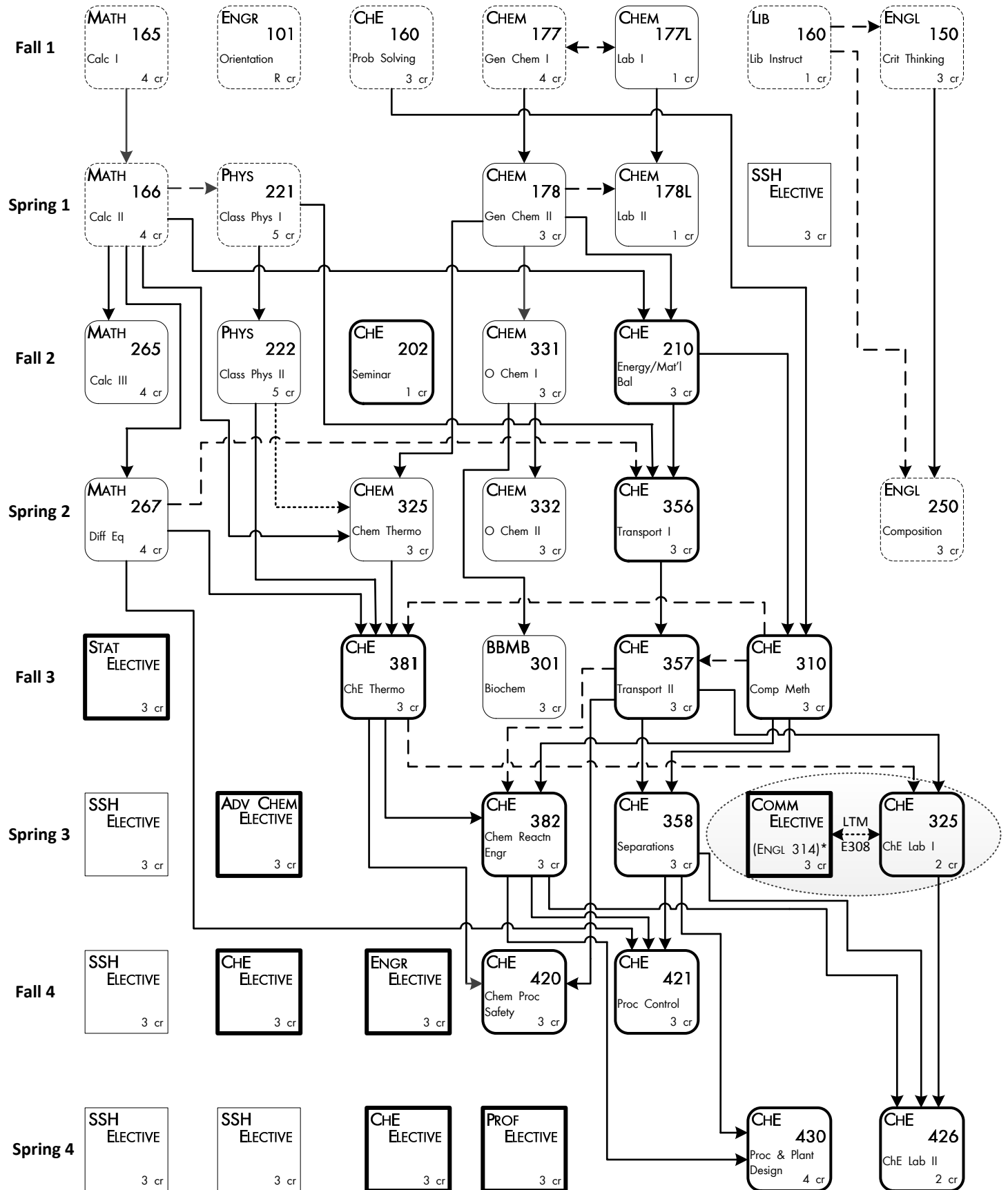

\* LTM E308 consists of taking specific sections of Engl 314 and ChE 325 together.

# CHEMICAL ENGINEERING FLOWCHART, 2014-15 CATALOG (129 CREDITS)

(ALTERNATIVE)

Term/Year

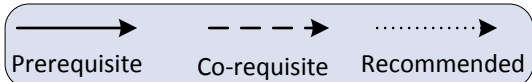
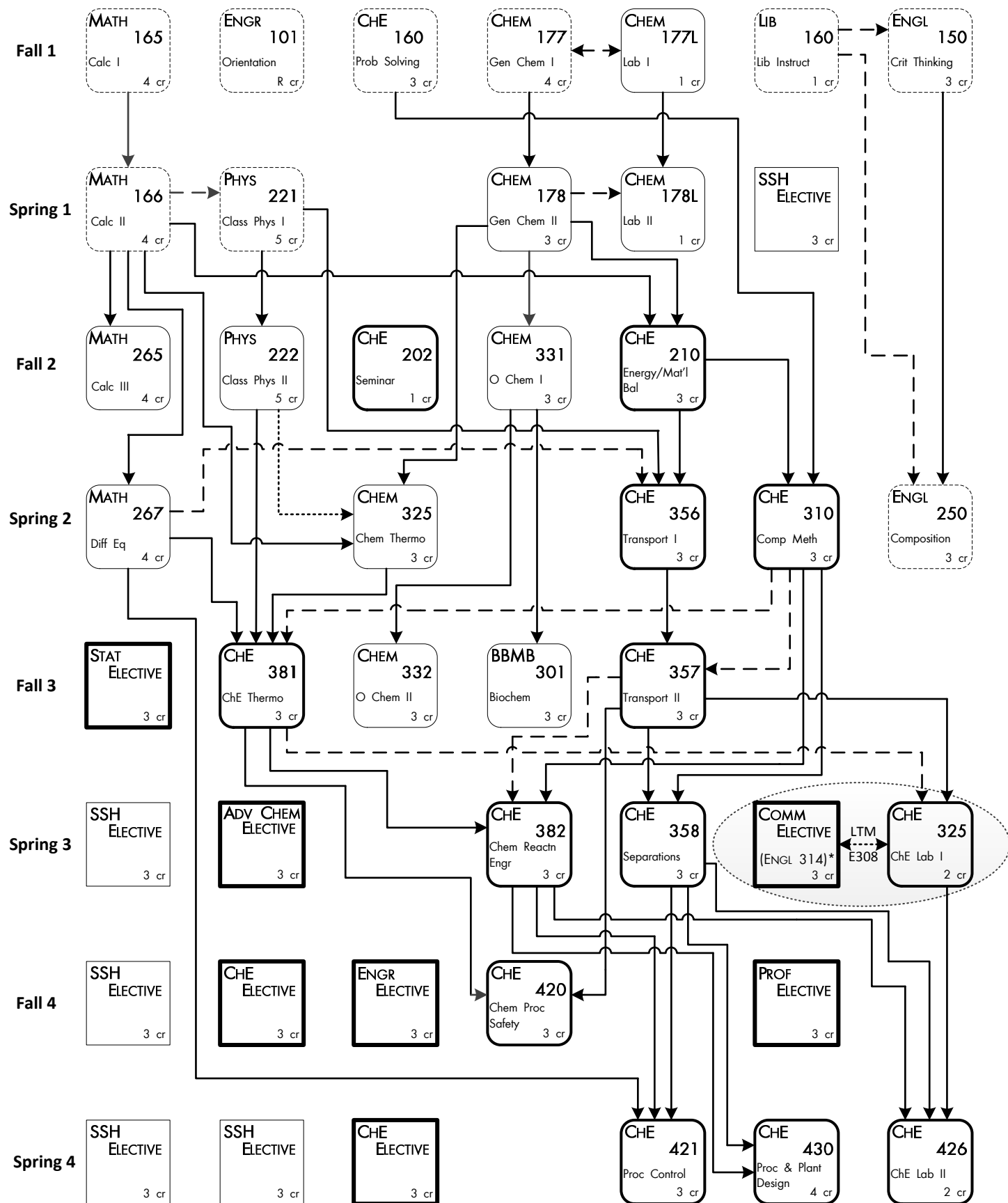

\* LTM E308 consists of taking specific sections of Engr 314 and ChE 325 together.

# Undergraduate Curriculum in Chemical Engineering

2014-15 Catalog  
Total Credits = 129

## First Year (32)

### Fall Semester (16)

4	+ MATH 165	Calculus I
3	+ ENGL 150	Crit. Think. & Comm.
4	+ CHEM 177	General Chemistry I
1	CHEM 177L	General Chemistry I Lab
3	+ CH E 160	Chem. Engr. Problems
R	+ ENGR 101	Engineering Orientation
1	+ LIB 160	Information Literacy

### Spring Semester (16)

4	+MATH 166	Calculus II
3	CHEM 178	General Chemistry II
1	CHEM 178L	General Chemistry II Lab
5	+PHYS 221	Intro. to Physics I
3		SSH Elective

## Second Year (32)

### Fall Semester (16)

3	* CH E 210	Material & Energy Bal.
4	MATH 265	Calculus III
5	PHYS 222	Intro. to Physics II
3	CHEM 331	Organic Chemistry I
1	* CH E 202	Seminar

### Spring Semester (16)

3	* CH E 356	Transport Phenomena I
4	MATH 267	Differential Equations
3	CHEM 332	Organic Chemistry II
3	CHEM 325	Chemical Thermodynamics
3	+ENGL 250	Written/Oral/Vis/Elect. Comp.

## Third Year (32)

### Fall Semester (15)

3	* CH E 310	Computational Methods in ChE
3	* CH E 357	Transport Phenomena II
3	* CH E 381	ChE Thermodynamics
3	BBMB 301	Biochemistry
3		Statistics Elective

### Spring Semester (17)

3		Communication Elective	} ☆
2	* CH E 325	ChE Laboratory I	
3	* CH E 358	Separations	
3	* CH E 382	Chemical Reaction Engr	
3		Chemistry Elective	
3		SSH Elective	

## Fourth Year (33)

### Fall Semester (15)

3	* CH E 421	Process Control
3	CH E 420	Chemical Process Safety
3		Engineering Elective
3		ChE Elective
3		SSH Elective

### Spring Semester (18)

4	* CH E 430	Process and Plant Design
2	CH E 426	ChE Laboratory II
3		Professional Elective
3		ChE Elective
3		SSH Elective
3		SSH Elective

+ Basic Program – must earn a minimum 2.00 GPA and must be completed before enrolling in the 1<sup>st</sup> 200-level ENGR course. English may be taken concurrently.

\* CH E Core – must earn a minimum 2.00 GPA, including transfer credits

☆ LTM E308 consists of taking specific sections of ENGL 314 and CH E 325 together

# Undergraduate Curriculum in Chemical Engineering

2014-15 Catalog

Total Credits = 129

(prerequisites/\*co-requisites)

<b>Year 1</b>	F	<b>MATH 165</b> 4	<b>CHEM 177</b> (*CHEM 177L) 4	<b>CHEM 177L</b> (*CHEM 177) 1	<b>ENGL 150</b> 3	<b>LIB 160</b> 1	<b>CH E 160</b> 3	<b>ENGR 101</b> R	16
	S	<b>MATH 166</b> (MATH 165) 4	<b>CHEM 178</b> (CHEM 177) (CHEM 177L) 3	<b>CHEM 178L</b> (CHEM 177L) (*CHEM 178) 1	<b>SSH Elec</b> 3			<b>PHYS 221</b> (*MATH 166) 5	16

<b>Year 2</b>	F		<b>MATH 265</b> (MATH 166) 4	<b>CHEM 331</b> (CHEM 178) 3	<b>CH E 210</b> (CHEM 178) (MATH 166) 3	<b>CH E 202</b> 1	<b>PHYS 222</b> (PHYS 221) 5	16
	S	<b>ENGL 250</b> (ENGL 150) (*LIB 160) 3	<b>MATH 267</b> (MATH 166) 4	<b>CHEM 332</b> (CHEM 331) 3	<b>CHEM 325</b> (CHEM 178) (MATH 166) 3		<b>CH E 356</b> (CH E 210) (Phys 221) (*MATH 267) 3	16

<b>Year 3</b>	F	<b>STAT Elec</b> 3	<b>BBMB 301</b> (CHEM 331) 3	<b>CH E 381</b> (CHEM 325) (MATH 267) (PHYS 222) (*CH E 310) 3	<b>CH E 357</b> (CH E 356) (*CH E 310) 3	<b>CH E 310</b> (CH E 210) (CH E 160) 3		15
	S	<b>SSH Elec</b> 3	<b>CHEM Elec</b> 3	<b>CH E 382</b> (CH E 310) (CH E 381) (*CH E 357) 3	<b>CH E 358</b> (CH E 310) (CH E 357) 3	<b>CH E 325</b> (CH E 357) (*CH E 381) 2	<b>Comm Elec</b> 3	17

<b>Year 4</b>	F	<b>SSH Elec</b> 3		<b>ENGR Elec</b> 3	<b>CH E Elec</b> 3	<b>CH E 421</b> (MATH 267) (*CH E 358) (CH E 382) 3	<b>CH E 420</b> (CH E 357) (CH E 381) 3	15
	S	<b>SSH Elec</b> 3	<b>SSH Elec</b> 3	<b>Prof Elec</b> 3	<b>CH E Elec</b> 3	<b>CH E 430</b> (CH E 358) (CH E 382) 4	<b>CH E 426</b> (CH E 325) (CH E 358) (CH E 382) 2	18



# Undergraduate Curriculum in Chemical Engineering

## *Biological Engineering Option*

2014-2015 Catalog  
Total Credits = 129

### First Year (32)

<b>Fall Semester (16)</b>			<b>Spring Semester (16)</b>		
4	+ MATH 165	Calculus I	4	+MATH 166	Calculus II
3	+ ENGL 150	Crit. Think. & Comm.	3	CHEM 178	General Chemistry
4	+ CHEM 177	General Chemistry	1	CHEM 178L	General Chemistry Lab
1	CHEM 177L	General Chemistry Lab	5	+PHYS 221	Intro. to Physics I
3	+ CH E 160	Chem. Engr. Problems	3		SSH Elective
R	+ ENGR 101	Engineering Orientation			
1	+ LIB 160	Information Literacy			

### Second Year (32)

<b>Fall Semester (16)</b>			<b>Spring Semester (16)</b>		
3	* CH E 210	Material & Energy Bal.	3	* CH E 356	Transport Phenomena I
4	MATH 265	Calculus III	4	MATH 267	Differential Equations
5	PHYS 222	Intro. to Physics II	3	CHEM 332	Organic Chemistry II
3	CHEM 331	Organic Chemistry I	3	CHEM 325	Chemical Thermodynamics
1	* CH E 202	Seminar	3	+ENGL 250	Written/Oral/Vis/Elect. Comp.

### Third Year (32)

<b>Fall Semester (15)</b>			<b>Spring Semester (17)</b>		
3	* CH E 310	Computational Methods in ChE	3		Communication Elective } ☆
3	* CH E 357	Transport Phenomena II	2	* CH E 325	ChE Laboratory I
3	* CH E 381	ChE Thermodynamics	3	* CH E 358	Separations
3		Statistics Elective	3	* CH E 382	Chemical Reaction Engr
3	BBMB 301	Biochemistry <b>or</b>	3		SSH Elective
	BBMB 404	Biochemistry I <b>or</b>	3	BBMB 420	Physiological Chemistry <b>or</b>
	BIOL 313	Principles of Genetics		BBMB 405	Biochemistry II <b>or</b>
				BIOL 314	Molecular Cell Biology

### Fourth Year (33)

<b>Fall Semester (15)</b>			<b>Spring Semester (18)</b>		
3	* CH E 421	Process Control	4	* CH E 430	Process and Plant Design
3	* CH E 420	Chemical Process Safety	2	* CH E 427	Biological Engr Laboratory
3		ENGR Elective	3		Professional Elective
3		CH E Elective	3		CH E Elective
3		SSH Elective	3		SSH Elective
			3		SSH Elective

+ Basic Program – must earn a minimum 2.00 GPA and must be completed before enrolling in the 1<sup>st</sup> 200-level ENGR course. English may be taken concurrently.

\* CH E Core – must earn a minimum 2.00 GPA, including transfer credits.

☆ LTM E308 consists of taking specific sections of ENGL 314 and CH E 325 together

## Undergraduate Curriculum in Chemical Engineering *Biological Engineering Option*

2014-15 Catalog  
Total Credits = 129  
(prerequisites/\*co-requisites)

<b>Year 1</b>	F	<b>MATH 165</b> 4	<b>CHEM 177</b> (*CHEM 177L) 4	<b>CHEM 177L</b> (*CHEM 177) 1	<b>ENGL 150</b> 3	<b>LIB 160</b> 1	<b>CH E 160</b> 3	<b>ENGR 101</b> R	16
	S	<b>MATH 166</b> (MATH 165) 4	<b>CHEM 178</b> (CHEM 177) (CHEM 177L) 3	<b>CHEM 178L</b> (CHEM 177L) (*CHEM 178) 1	<b>SSH Elec</b> 3			<b>PHYS 221</b> (*MATH 166) 5	16

<b>Year 2</b>	F		<b>MATH 265</b> (MATH 166) 4	<b>CHEM 331</b> (CHEM 178) 3	<b>CH E 210</b> (CHEM 178) (MATH 166) 3	<b>CH E 202</b> 1	<b>PHYS 222</b> (PHYS 221) 5	16
	S	<b>ENGL 250</b> (ENGL 150) (*LIB 160) 3	<b>MATH 267</b> (MATH 166) 4	<b>CHEM 332</b> (CHEM 331) 3	<b>CHEM 325</b> (CHEM 178) (MATH 166) 3		<b>CH E 356</b> (CH E 210) (PHYS 221) (*MATH 267) 3	16

<b>Year 3</b>	F	<b>STAT Elec</b> 3	<b>1-BBMB 404</b> (CHEM 332) or <b>2-BBMB 301</b> (CHEM 331) 3	<b>CH E 381</b> (CHEM 325) (MATH 267) (PHYS 222) (*CH E 310) 3	<b>CH E 357</b> (CH E 356) (*CH E 310) 3	<b>CH E 310</b> (CH E 210) (CH E 160) 3		15
	S	<b>SSH Elec</b> 3	<b>CHEM Elec</b> 1-BBMB 405 (BBMB 404) or 2-BBMB 420 (CHEM 332) (BBMB 301) 3	<b>CH E 382</b> (CH E 310) (CH E 381) (*CH E 357) 3	<b>CH E 358</b> (CH E 310) (CH E 357) 3	<b>CH E 325</b> (CH E 357) (*CH E 381) 2	<b>Comm Elec</b> 3	17

<b>Year 4</b>	F	<b>SSH Elec</b> 3		<b>ENGR Elec</b> 3	<b>CH E Elec</b> 3	<b>CH E 421</b> (MATH 267) (*CH E 358) (CH E 382) 3	<b>CH E 420</b> (CH E 357) (CH E 381) 3	15
	S	<b>SSH Elec</b> 3	<b>SSH Elec</b> 3	<b>Prof Elec</b> 3	<b>CH E Elec</b> 3	<b>CH E 430</b> (CH E 358) (CH E 382) 4	<b>CH E 427</b> (CH E 325) (CH E 358) (CH E 382) 2	18

## Electives

The chemical engineering curriculum provides considerable flexibility, which allows you to tailor the curriculum to meet your own needs. The elective requirements are in social sciences/humanities and in technical areas including communication.

You are strongly encouraged to take the LTM E308 learning community that integrates the writing component of ENGL 314 with the lab reports in CH E 325. This provides you with the advantage of extra help with your written reports and joint assignments that are submitted to both classes.

The chemical engineering curriculum includes 21 credits of technical electives, which provide students the opportunity to develop a deeper understanding of additional areas of science and engineering. You are encouraged to carefully plan your elective choices. Elective planning **MUST** be done in consultation with your faculty mentor and the choices must be clearly identified on your curriculum Plan of Study (POS) (see p. 14).

Technical electives can be selected to develop a breadth of knowledge or to establish an “area of emphasis.” For example, you may wish to take a broad range of courses to prepare for graduate school. Alternatively, you may wish to focus your studies to develop a stronger background in an area of emphasis, such as biochemical engineering or solid state materials processing. Suggestions for several additional areas of emphasis are listed on pages 22-24. Your faculty adviser also can assist you in preparing an emphasis not currently listed on those pages. Be sure to plan early enough to permit taking necessary prerequisites. **No more than six credits total of CH E 490 or other STEM departmental independent/research study may be counted toward technical electives.**

**Important Note:** Some of the classes that are listed in the Iowa State University Catalog as prerequisites for the technical electives listed on the following page may apply only to people in that specific area of study. Prerequisites may be waived by the course instructor if the course is being taken by someone outside of that department’s curriculum. *Always consult with your adviser and course instructor about waiving any prerequisites for your technical electives.*

The various elective requirements are listed in Tables I and II.

**Table I - Electives**

	<b>MINIMUM CREDITS</b>
<b>Social Science &amp; Humanities electives:</b> (see pages 9-12)	<b>15</b>
<b>Technical Electives</b>	<b>21</b>
<b>Communications electives:</b> ENGL 309, ENGL 312, ENGL 314, or JL MC 347	3
<b>Advanced Chemistry electives:</b> AGRON 320 BBMB 404, 405, 411, 420, 461 CE 420 or ENSCI 459 CHEM 211, 211L, 301, 316, 316L, 321L, 322L, 324, 331L or 333L, 332L or 334L, 401L, 402 FS HN 311, 311L, 410	3
<b>Statistics electives:</b> STAT 305, 231, 341, 342, 401, 495, 496, MAT E 316	3
<b>Chemical Engineering electives:</b> These include CH E 406, 408, 415, 440, 447**, and any other 300+ CH E course not specified as required in the curriculum	6
<b>Engineering electives:</b> Any 300+ engineering course outside of chemical engineering that does not repeat material in required ChE courses nor on SSH list. Approved exceptions: AER E 261, BioE 220, CPR E 281, EE 201, EM 274, and MAT E 273 Consult mentor for approval.	3
<b>Professional electives:</b> 300+ Physical Science, Life Science, Engineering, Statistics, Mathematics, or Computer Science not on SSH list Approved exceptions: MATH 207, MICRO 201, 201L, and those approved for Engineering & Advanced Chem electives.	3

\* Courses not allowed as Technical Elective due to content overlap with required CH E courses: AE 316/BSE 316, 402, 411; AER E 446, EM 378, MAT E 311, ME 332, 335, 411, 421, 436, 475;

\*\* Only one of Ch E 447 or Mat E 351 may count toward graduation.

## Biological Engineering Option

You may enhance your academic preparation for the growing opportunities in the biological-related industries by adding the biological engineering option to the standard chemical engineering program. In addition to the elective choices listed in Table II below, you may replace BBMB 301 with BBMB 404 and BBMB 405. BBMB 405 can be used to meet the Chemistry Elective. CH E 426 may be replaced by CH E 427.

**Table II – Electives for Biological Engineering Option**

	<b>MINIMUM CREDITS</b>
<b>Social Science &amp; Humanities electives:</b> (see page 10)	<b>15</b>
<b>Technical Electives</b>	<b>21</b>
<b>Communications electives:</b> ENGL 309, 312, 314, or JL MC 347	3
<b>Advanced Chemistry electives:</b> BBMB 405, 411, 420, 451	3
<b>Statistics electives:</b> STAT 305, 231, 341, 342, 401, 495, 496, or MAT E 316	3
<b>Chemical Engineering electives:</b> CH E 415, 440, 542, 562	6
<b>Engineering electives:</b> BIOE (Approved), BRT 501, CE 421, BSE 480, AE 380, MSE 580	3
<b>Professional electives:</b> CH E 415, 440, 542, 562, 490 OR one APPROVED course from: 300+ Life Science (BIOL 314), CHEM, FS HN, or BBMB (not BBMB 301) and not on SSH list	3

## Suggested Emphases for Technical Electives (prerequisites & \*co-requisites)

Listed below are courses that you may consider taking as part of your package of electives for a desired career path. These lists are not exhaustive, and sometimes more courses are suggested than a student has time to take. You should work closely with your faculty mentor to choose an appropriate set of electives to suit your individual career goals.

### General Graduate School Preparation

#### Chemistry/Professional Electives

CHEM 324 (3) Introductory Quantum Mechanics (CHEM 178, MATH 166, Phys 222)

#### CH E/Professional Electives

CH E 408 (3) Surface and Colloid Chemistry (CH E 381)

CH E 415 (3) Biochemical Engineering (CH E 357, CH E 382, and CHEM 331)

CH E 447 (3) Polymers and Polymer Engineering (CH E 382 and CHEM 331 or MatE 351) – only CH E 447 or MAT E 351 can be used to meet degree requirements

CH E 490 (variable) Research/Independent Study

CH E 545 (3) Analytical and Numerical Methods (CH E 358 and MATH 267)

CH E 500-level courses

#### Engineering Elective

EE 201 (4) Electric Circuits

EM 274 (3) Statics of Engineering

## Professional Electives

- MATH 207 (3) Matrices and Linear Algebra (2 semesters of calculus)
- MATH 385 (3) Introduction to Partial Differential Equations (MATH 265 and MATH 267)

## General Industrial Preparation

### Advanced Chemistry Elective

- CHEM 211/211L (2/2) Quantitative and Environmental Analysis/Lab
- CHEM 301 (2) Inorganic Chemistry

### CH E/Professional Electives

- CH E 406 (3) Environmental Chemodynamics (CH E 381 and \* CH E 358)
- CH E 408 (3) Surface and Colloid Chemistry (CH E 381)
- CH E 415 (3) Biochemical Engineering (CH E 357, CH E 382, and CHEM 331)
- CH E 447 (3) Polymers and Polymer Engineering (CH E 382 and CHEM 331 or MAT E 351)) – only CH E 447 or MAT E 351 can be used to meet degree requirements

### Engineering/Professional Electives

- IE 305 (3) Engineering Economic Analysis (Math 166)
- EM 274 (3) Statics of Engineering

## Biochemical Engineering

### Chemistry/Professional Electives

- BBMB 404 (3) Biochemistry I (CHEM 332) (recommend to replace BBMB 301)
- BBMB 405 (3) Biochemistry II (BBMB 404)
- BBMB 420 (3) Physiological Chemistry (CHEM 332, BBMB 301 or Biol 314) – Only credit from either BBMB 404&405 or BBMB 420, not both, may be applied to graduation

### CH E/Professional Electives

- CH E 415 (3) Biochemical Engineering (CH E 357, CH E 382, and CHEM 331)
- CH E 562 (3) Bioseparations (CH E 357)

### Engineering/Professional Electives

- CE 421 (3) Environmental Biotechnology (CE 326)

### Professional Elective

- MICRO 201 (2) General Microbiology (one semester of biology)
- BIOE 411 (3) Bioprocessing and Bioproducts (AE 216, MATH 165, CHEM 177, BIOL 173 or 211 or higher)
- BRT 501 (3) Fundamentals of Biorenewable Resources (senior or graduate classification)

## Biomedical Engineering

### Chemistry/Professional Electives

- BBMB 404 (3) Biochemistry I (CHEM 332) (recommend to replace BBMB 301)
- BBMB 405 (3) Biochemistry II (BBMB 404)

### CH E/Professional Electives

- CH E 415 (3) Biochemical Engineering (CH E 357, CH E 382, and CHEM 331)
- CH E 440 (3) Biomedical Applications of Chemical Engineering (ChE 210, MATH 266, and Phys 222)
- CH E 562 (3) Bioseparations (CH E 357)

### Engineering/Professional Electives

- EE 201 (4) Electric Circuits
- BIOE 220 (3) Introduction to Biomedical Engineering
- BIOE 341 (3) BioMEMs and Nanotechnology (BIOE 202)
- BIOE 352 (3) Molecular, Cellular, and Tissue Biomechanics (BIOE 220, EM 324, MAT E 273)
- BIOE 450 (3) Biosensing (BIOE 202)

### Professional Electives

- BIOL 313 (3) Principles of Genetics (BIOL 211, 211L, 212, 212L)
- BIOL 314 (3) Principles of Molecular Cell Biology (BIOL 313)

## Environmental Science and Engineering

### Chemistry/Professional Electives

- CE 420 (3) Environmental Engineering Chemistry (CE 326, CHEM 177, CHEM 178, MATH 166)

### CH E/Professional Electives

- CH E 406 (3) Environmental Chemodynamics (CH E 381 and \* CH E 358)
- CH E 408 (3) Surface and Colloid Chemistry (CH E 381)

### Engineering/Professional Electives

- CE 326 (3) Principles of Environmental Engineering (CHEM 178, MATH 166, and \*EM 378)

CE 421 (3) Environmental Biotechnology (CE 326)  
CE 428 (3) Water and Wastewater Treatment Plant Design (CE 326)  
CE 529 (3) Hazardous Waste Management (CE 326)

Professional Electives

ENVSCI 324 (3) Energy and the Environment

## Food Engineering

Chemistry/Professional Electives

FS HN 311 (3) Food Chemistry (FS HN 203, TSM 115, CHEM 331 and CHEM 331L, and \*BBMB 301)

CH E/Professional Electives

CH E 408 (3) Surface and Colloid Chemistry (CH E 381)

CH E 415 (3) Biochemical Engineering (CH E 357, CH E 382, and CHEM 331)

Engineering/Professional Electives

A E 451 (3) Food and Bioprocess Engineering (ChE 357 or FS HN 351 and MATH 267)

Professional Electives

FS HN 412 (4) Food Product Development (FS HN 311 or FS HN 411 and FS HN 471)

FS HN 420 (3) Food Microbiology (MICRO 201 or MICRO 302)

FS HN 421 (3) Food Microbiology Laboratory (MICRO 201/201L or 302/302L, FS HN 420\*, FS HN 203\*)

FS HN 471 (3) Food Processing (MICRO 201 or MICRO 302)

FS HN 472 (2) Food Processing Lab (FS HN 351, FS HN 471\*)

## Materials Science

CH E/Professional Electives

CH E 440 (3) Biomedical Applications of Chemical Engineering (CH E 210, MATH 266, PHYS 222)

CH E 447 (3) Polymers and Polymer Engineering (CH E 382 and CHEM 331 or MAT E 351) – only

CH E 447 or MAT E 351 can be used to meet degree requirements

Chemistry/Professional Electives

CHEM 301 (2) Inorganic Chemistry - non-metals (CHEM 324)

MAT E 454 (3) Polymer Composites and Processing (MAT E 351)

Engineering Elective

MAT E 273 (3) Principles of Materials Science and Engineering (CHEM 177, MATH 165)

Professional Elective

PHYS 321 (3) Introduction to Modern Physics I (PHYS 222 and MATH 266\*)

\* Credit or Enrollment in

## Bioengineering Minor

This program is open to all undergraduate engineering students at Iowa State University. This minor will provide students with a foundation of core biology and engineering concepts relevant to further study in biomedical engineering. In addition, students will receive an introduction to the application of engineering principles to biomedical problems from a multidisciplinary perspective as well as the applications within the majors of the participating departments. Minor requirements are as follows:

A minimum of 16 credits meeting the 6 course requirements below; a minimum of 9 credits must not be applied towards other degree requirements; and a minimum of 6 credits must be taken at the 300-level or above.

Note: Most students will need to complete 18 credits to fulfill all of the requirements of this minor.

BIOL 212	Principles of Biology II	3
BIOE 220	Introduction to Biomedical Engineering	3
BIOL 256	Fundamentals of Human Physiology	3
INTRO ENGR ELEC <sup>1</sup>		3
ADV ENGR ELEC <sup>2</sup>		3
PROF ELEC <sup>3</sup>		1-3

<sup>1</sup> A second (Introductory) Engineering Course from a department other than that of your major and that is not duplicative of material in a course taken in your own department. The topic of the course should have ready application to later BME-related electives in that discipline (MATE 273, EM 274 or 324, CH E 210, EE 201, or EE 230, or other courses approved by Minor Chair).

<sup>2</sup> 300-500 Level Engineering course with clear Biomedical Engineering application (BIOE 325, 341,341L, 352, 411, BIOE 428, 450, 450L, 490; CH E 440, 542; MAT E 456; IE 571; or other courses approved by Minor Chair).

<sup>3</sup> 300-500 Level Engineering or life sciences course with clear Biomedical Engineering application OR BIOE 490 or departmental 490 with biomedical engineering topic OR 200+-level life sciences laboratory course (if a 200-level course is chosen here, the student will need to meet the required 6 credits of 300+ by substitution of a higher-level course for another requirement or taking an additional course).

## Policies

### Transfer Credits

1. By departmental policy, transfer grades of C- or lower are not accepted for curriculum requirements.
2. A maximum of 65 credits from a 2-year school can be applied to degree requirements.
3. The last 32 credits of the degree program must be at Iowa State University. Exceptions may be granted in special cases. Meet with your adviser.
4. Transfer students with transfer credits in chemical engineering core courses must earn at least 15 semester credits in Iowa State University courses in this category at the 300-level or above to qualify for the B.S. degree in chemical engineering.

### English Proficiency Requirement

Beyond the completion of the freshman composition courses, ENGL 150 and ENGL 250, certification of English proficiency is the responsibility of the student's major department. In chemical engineering, certification is accomplished by successful completion of the communication elective (ENGL 309, ENGL 312, ENGL 314, or JL MC 347).

Students whose first language is not English must pass an English proficiency examination before taking ENGL 150. A student not passing the exam must enroll each semester in a special English program until the minimum standards are met. This English program is designed to improve English skills resulting in increased success in coursework.

### Diversity/International Perspectives

All ISU students must complete a diversity requirement of three credits and an international perspectives requirement of three credits. Consult the lists shown on pages 10 - 12 for courses that also are on the accepted SSH course list and <http://www.registrar.iastate.edu/courses/div-ip-guide.html> for a more complete list of courses that will meet either the U.S. Diversity or International Perspective requirements.

### Graduation Requirements

You are able to obtain a copy of your degree audit at any time in AccessPlus. You should check each semester to ensure that each course taken or transferred is properly applied to the correct curricular category. Ask your academic adviser to make any necessary corrections to your degree audit to ensure everything is correct by the semester preceding your expected term of graduation. Students will need to fill out an Application for Graduation (available on AccessPlus) at the same time as registering for the term they plan to graduate. The applications will be accepted during the registration period for the graduation term. Degree audits will be printed during the first week of classes for students who submit the application by the week before the first day of the semester they plan on graduating. **Late submissions result in not having a degree audit printed.**

### Pass-Not Pass Policy

A maximum of nine Pass-Not Pass semester credits may be used to meet graduation requirements. Courses offered on a Satisfactory-Fail basis may not be taken on a Pass-Not Pass basis.

Pass-Not Pass credits can be applied toward requirements for a B.S. degree in chemical engineering only if the course is specified in the curriculum as a social science and humanities elective or is a course not used in the degree program. Pass-Not Pass credits are not acceptable for technical elective courses or for courses used to satisfy the U.S. Diversity or International Perspectives requirements.



## **Part 3: Opportunities for Undergraduates**

## International Studies in Chemical and Biological Engineering

The CBE department has established one of the most active international study programs at Iowa State University. These programs have been recognized as being some of the leading internationalization efforts for American chemical engineering departments. Through these programs you have the opportunity to:

- ❖ Study for 1-2 semesters at prominent chemical engineering departments in Europe, Asia, or Australia
- ❖ Participate in a 5-6 week summer school course in Oviedo, Spain
- ❖ Gain international work experience with a global corporation in conjunction with an academic exchange

A summary of the programs available to chemical engineers is provided below. You are urged to contact the program coordinators for more information. Several of the programs have application due dates that you should carefully note.

### International Summer Study Program

The CBE department has a summer study program in Oviedo, Spain, available to juniors, seniors, and qualified sophomores involving a chemical engineering laboratory course.

#### University of Oviedo Summer Laboratory Program

This 5-week program offers the opportunity to complete a lecture and laboratory course at the University of Oviedo and to compare the technical and cultural aspects of the U.S. and Spain. Ample opportunities to travel in Europe are available for those deciding to do so. Students from University of Wisconsin-Madison also participate in the Oviedo program.

Iowa State students who participate in this program earn seven semester credits in CH E 391 and CH E 392, which apply toward the B.S. requirements (four credits substitute for CH E 325 and CH E 426 and three credits may apply to the SSH requirement). The credits are given on the basis of participating in the following:

- ❖ An orientation course (CH E 391) during spring semester at Iowa State;
- ❖ Lectures attended and laboratory experiments performed during a five-week program at the University of Oviedo;
- ❖ Visits to Spanish chemical engineering departments, research laboratories, and manufacturing facilities, mostly during the third week of the program.

The cost of the program (excluding personal entertainment and transportation costs) is about \$6,000 for Oviedo. Loans and foreign study grants are available to qualified applicants.

Applications for these programs are due in the fall, usually by mid-November.

For further information, contact Dr. Charles Glatz, 2149 Sweeney Hall
--

### International University Exchanges

The CBE department administers several highly successful university exchanges with international universities. The mutual exchange agreements involve several of the leading chemical engineering departments in Europe, Australia and Asia. Students generally attend for one to two semesters, perhaps with a travel period coordinated with the university schedules. Coursework is sufficiently similar at these universities so that students are able to continue their degree program at Iowa State without interruption. The exchanges allow students to develop a better cultural and social understanding of the host country and to participate more fully in a new academic experience. Most students have formed lasting contacts with classmates and faculty.

The programs are organized according to Iowa State procedures established through the Iowa State University Study Abroad Center. This includes:

- ❖ Applying for the program at specific dates (see each program below)
- ❖ Registering and paying tuition and fees as if remaining at ISU, but selecting course work at the international university
- ❖ Paying no fees at the international university, but providing your own transportation and living costs
- ❖ Receiving credit for the courses towards your degree

Specific arrangements for each program differ slightly; contact the program coordinator for each exchange.

Visit the Engineering International Engagement website, <http://www.engineering.iastate.edu/studyabroad>, or email [eip@iastate.edu](mailto:eip@iastate.edu) for general questions about study abroad and the application process.

### **National University of Singapore**

The National University of Singapore consists of nearly 23,000 students studying in the disciplines of engineering, science, business administration, architecture and building, arts and social sciences, dentistry, law, and medicine. NUS has been recognized as one of the premier universities in southeast Asia. Excellent laboratory, equipment, and library facilities are to be found on this spectacular urban campus in modern Singapore. All classroom instruction is in English.

For further information, contact Dr. Kurt Hebert, 3133 Sweeney Hall or  
Dr. Say Kee Ong, 486 Town Engineering Building.  
You should start your plans 6-8 months before your planned departure to Singapore.  
The application deadline is October 1 for spring semester and March 1 for fall semester.

### **Monterrey Tec**

The Tecnológico de Monterrey (Monterrey Tec) is the premier undergraduate engineering institute in Mexico, covering nearly all engineering disciplines. It was the first in Mexico and one of the first outside the U.S. to be accredited by the Accreditation Board for Engineering and Technology. The Tec campus is located within a bus ride of the center of Monterrey, Mexico's third largest city. Just above it are the first ranges of the Sierra Maestre Oriental.

A working knowledge of Spanish is required, as most courses at Monterrey Tec are taught in it.

For general information, contact Dr. Peter Reilly, [reilly@iastate.edu](mailto:reilly@iastate.edu),  
or Nancy Guthrie, Study Abroad Center, 3224 Memorial Union.

### **University College London – Chemical and Biochemical Engineering**

An exchange program for chemical engineering juniors has been established with chemical engineering. The program is for the complete academic year with two different sets of courses to be taken depending on whether you want traditional chemical engineering or a biochemical engineering emphasis.

For further information, contact Dr. Charles Glatz, [cglatz@iastate.edu](mailto:cglatz@iastate.edu).  
Plan to apply to UCL in early spring for the following year.

### **University of Limerick, Ireland**

The campus, located on the banks of the River Shannon, lies at the heart of the 600-acre National Technological Park, three miles outside the city of Limerick. The university currently houses a population of some 9,000 students.

For further information, contact Dr. Frank Peters, 3024 Black Engineering Building.  
You should start your plans 6-8 months before your planned departure to Ireland.

## Swiss Federal Institute of Technology — Lausanne

Iowa State has had an exchange program with the Swiss Federal Institute of Technology (EPFL) in Lausanne since 1984. Students exchange on a one-for-one basis. Iowa State students pay tuition to Iowa State and room and board in Lausanne. The exchange is for a full year, and roughly 30 credits toward graduation should be earned by a student taking a full course load.

EPFL is a world-class engineering and science university. It covers all engineering disciplines found at Iowa State, except agricultural and industrial engineering. In addition, it offers physics, chemistry and mathematics. Courses are taught in French. Humanities and language courses can be taken at the adjacent University of Lausanne.

EPFL offers scholarships of Swiss francs 4,500 (approximately \$5,100 at the January 2014 exchange rate) to ISU engineering students.

The requirements for participation are a GPA of 3.0, junior standing at time of leaving, and three years of university-level French (those with less can take intensive French during the preceding summer in Switzerland).

For further information, contact Dr. Peter Reilly, [reilly@iastate.edu](mailto:reilly@iastate.edu).  
The application deadline for the following spring is October 15 and March 15 for a year-long exchange.

## Bogaziçi University (BU) & Middle East Technical University (METU) — Turkey

Bogaziçi University and Middle East Technical University are two of the most prestigious universities in Turkey. Bogaziçi University was founded as the first American higher education institution outside the U.S. as Robert College. Bogaziçi offers extensive coursework taught in English. It has most of the engineering programs including chemical engineering. Located only five minutes from the Bosphorus Strait, the university is in the heart of Istanbul. For more information about the university, see their website at <http://www.boun.edu.tr/en-US/Index>.

Middle East Technical University was founded in 1956 with academic and administrative assistance from USA. METU offers extensive coursework taught in English. The Engineering College offers 14 degree programs including chemical engineering (with three of their faculty being graduates of ISU) and the engineering undergraduate enrollment is significantly larger than at ISU. Located in the outskirts of the capitol city of Ankara on a beautiful campus, it provides an excellent setting for both academic and extracurricular activities. For more information about the university, see their web site at <http://www.metu.edu.tr/>. For more information about Turkey, visit the Turkish Embassy website at: <http://www.washington.emb.mfa.gov.tr/default.aspx>.

Students who are interested in applying for the BU or METU exchange program must be full-time engineering students at ISU and have an overall GPA of 3.0 or higher. No knowledge of Turkish is needed for the exchange program, but students are encouraged to learn some conversational Turkish prior to departure.

Applications include the application form, an unofficial transcript from ISU, two letters of reference, and a 250-word statement of purpose. Applications should be completed by early October.

Dr. Charles Glatz, [cglatz@iastate.edu](mailto:cglatz@iastate.edu), is the ChE contact.  
Contact Dr. Mufit Akinc, 2240L Hoover Hall, or Dr. Halil Ceylan, 406 Town  
Engineering Building, for other details.  
Applications should be completed by early October.

## Other International Opportunities

Additional programs that offer opportunities for chemical engineering students to study or work abroad are handled by the Engineering International Engagement office and Iowa State's Study Abroad Center. More information is available by visiting the following websites:

- ❖ Engineering International Engagement: <http://www.engineering.iastate.edu/studyabroad/>
- ❖ Study Abroad Center: <http://www.studyabroad.iastate.edu/>

## Honors Program

Students with high ability and clear educational objectives are encouraged to investigate the opportunities offered by the university Honors Program. The Honors Program emphasizes the development of individualized programs of study to meet the needs of students who have demonstrated the ability and maturity to assume more than the usual degree of responsibility for their education. The Honors Program also offers the opportunity to take Honors courses and Honors seminars, to make arrangements to take almost any course for Honors credit, and to carry out individual projects of an original, scholarly nature. Graduation as a member of the Honors Program is noted on the student's diploma, permanent record, and in the commencement program.

An undergraduate student who has a cumulative grade point average of 3.50 or greater may apply for the program during the second semester of residence or thereafter. A student must participate for a minimum of 48 credit hours. Students with lower grade point averages may be admitted providing they appear to have unusual potential or have demonstrated outstanding scholastic ability in other ways.

More information about the program can be obtained from Dr. Eric Cochran, 1035 Sweeney Hall; Dr. Kurt Hebert, 3133 Sweeney Hall; Dr. Jim Hill, 3155 Sweeney Hall; Dr. R. Dennis Vigil, 3037 Sweeney Hall; or Dr. Surya Mallapragada, 2031 Sweeney Hall; who all serve as mentors to chemical engineering students in the Honors program.

Information also can be obtained from the Honors Program Office in the Jischke Honors Building and from students currently participating in the program.

## Undergraduate Research Program and Independent Study

Students may participate in a special undergraduate research program or may pursue independent study through CH E 490. These opportunities may be particularly valuable for students planning to obtain an advanced degree or for students desiring work in a specific industry.

Students considering future research studies (such as graduate school) or employment in industrial or academic research may participate in a special undergraduate research program by registering for CH E 490. Students are strongly encouraged to participate for two semesters. Students may participate in special meetings covering topics such as: the methodology of conducting scientific research, the status of the research in industry and academia, ethics and scientific professionalism, safety, general opportunities for graduate research in chemical engineering, application procedures for graduate school, availability of national fellowships, and specific research opportunities at Iowa State. They may attend group meetings on a regular basis and will be encouraged to attend the graduate research seminar (CH E 601).

Students may also participate in a special topics project involving independent study by registering for CH E 490. These projects may include literature studies/reviews, completion of the American Institute of Chemical Engineers Student Design Contest Problem, setting up a laboratory experiment, etc.

You will select these projects by consultation with individual faculty members. Election of course and topic must be approved in advance by project supervisor and adviser with the completion of a CH E 490 Study Proposal form available for download at <http://www.cbe.iastate.edu/current-students/forms>. Upon completion of the project, you will submit a written report to the faculty coordinator. Participation in regional student AIChE chapter meetings is also anticipated for outstanding contributions. **No more than six credits total of CH E 490 or other departmental independent/research study may be counted towards technical electives.**

Honors program students may participate by registering for CH E 490H.

## Faculty and Their Research Interests

(<http://www.cbe.iastate.edu/research/>)

Students should contact faculty members directly if they are interested in working for them.

**Mufit Akinc** – Processing of advanced materials, solid-liquid and solid-gas interface, synthesis of nano powders, fibers. Design and development of materials for ultra-high temperature applications, infrared transmitting oxides, insulation materials.

**Kaitlin Bratlie** – We are interested in understanding biomolecule interactions with polymers through optical techniques to engineer materials for drug delivery and tissue engineering applications. The relationship between structure and the foreign body response is of great interest. We employ whole animal fluorescence imaging, nonlinear optical imaging, and a variety of biochemical assays to study these phenomena.

**Robert Brown** – The use of biorenewable resources (crops and biomass) as a source of chemicals and energy is the focus of our research activities. Combustion and gasification in fluidized bed for electric power production is one aspect of our work. In collaboration with fermentation experts, we are also evaluating a hybrid thermal/biological process to convert lingo-cellulose into alcohols and acids.

**Rebecca Cademartiri** – We are studying the interactions of biological moieties (e.g., bacteriophages, proteins, cells) with materials to generate rules which govern conjugation. Understanding the underlying rules will help us to quickly adapt our biology/materials conjugates to new challenges (e.g., different chemical environments during pathogen detection in water). As an example, simple charge based interactions will allow us to easily exchange one type of bacteriophage (a virus against bacteria) with another one to counter possible resistance of bacteria. We are also interested in the release profiles of biological moieties from materials. Formulating rules on how biomolecules release from materials, e.g., depending on the charge and density of the material and the environmental conditions, will allow us to produce slow-release systems, e.g., drug-delivery systems with high adaptability to emerging diseases.

**Eric Cochran** – My research group combines the principles of thermodynamics with polymer chemistry to design new polymeric materials that possess advanced characteristics currently unavailable from the modern commodity plastics industry. Of various types of systems, we commonly use the thermodynamics of phase separation to create highly ordered structures with feature sizes from 10-100 nm (a nanometer is 1 billionth of a meter). The applications in which we are interested vary from flame resistant materials, to highly elastic materials, to high performance fuel cell membranes, to liquid crystal display technologies, or even controlled drug delivery.

**Rodney Fox** – Computation and modeling of turbulent reacting flows and fluid dynamics applied to the chemical process industry, applied mathematics with emphasis on stochastic processes, and high-end computing and visualization engineering applications.

**Kurt Hebert** – Many materials used in structures and devices are intrinsically reactive with their environments and depend on thin surface film, formed by oxidation, for protection against degradation by corrosion. When corrosion does initiate on oxide-covered metals, it is typically confined to sites where the corrosion rate is very high. Our research goal is to develop a fundamental understanding of critical chemical and physical processes involved in localized corrosion to effectively control it.

**James Hill** – We study problems of turbulent transport and mixing using statistical turbulence theory and direct numerical simulations. With the latter, all details of the three-dimensional, unsteady fluid motion are resolved. This work is coupled with laboratory experiments using modern laser diagnostic techniques (PIV and PLIF) to validate computational fluid dynamics (CFD) procedures.

**Andrew Hillier** – My research group performs exploratory experimental studies that encompass topics from chemistry, materials science, catalysis, electrochemistry and interfacial engineering. Our activities focus on combinatorial experimental systems, fuel cell catalysts, responsive polymer membranes, synthesis and characterization of new materials, and the application of in-situ imaging techniques for characterization of the structure and chemistry of solid-liquid interfaces.

**Laura Jarboe** – Our research is focused on the engineering of biological systems. This includes modifying biological systems to do something useful, such as produce biorenewable compounds or increasing our understanding of how these biological systems work. Work is particularly focused on the sensitivity of bacteria to inhibitory compounds. Overcoming this inhibition is important for the economically viable production of biorenewable fuels and chemicals.

**Duane Johnson** – Theoretical materials chemistry and physics, surface and supported nanoparticle heterogeneous catalysis, alloy design and characterization, electronic-structure technique develop applications, thermodynamics and multi-scale modeling.

**Monica Lamm** – We use molecular simulation to discover and interpret fundamental relationships between molecular structure and thermodynamic properties in advanced materials used in applications such as pharmaceuticals, electronic and optical devices, environmentally responsive coatings, membrane separations, and energy storage.

**Surya Mallapragada** – We develop and investigate polymeric biomaterials and bioinspired materials for drug delivery, tissue engineering, and gene delivery.

**Balaji Narasimhan** – Nanoscale manipulation of polymer surfaces/interfaces, engineered biomaterials, controlled drug/protein/vaccine delivery, combinatorial materials science.

**Derrick Rollins** – Our research involves informatics, mathematical modeling and process control in biomedical engineering, material science, non-destructive evaluation (NDE), and data mining. A biomedical engineering focus is in diabetes clinical research modeling the glucose response of type 1 and type 2 diabetics with the goal of improved glucose control. We are developing non-invasive monitoring systems and an artificial pancreas based on control technology and modeling. We are modeling the human thermoregulatory system to diagnose human health and diseases to improve health. Our data mining work focuses on applying multivariate statistical methods to improve identification of critical genes in a number of health science and biotechnology applications. We are developing NDE test methods to determine the ballistic integrity of armor for soldiers and vehicles.

**Ian Schneider** – Our research group is interested in understanding fundamental cellular behavior that drives the progression of disease states. This behavior includes cell migration, cell adhesion, and cell-cell communication. We use an array of quantitative biochemistry and microscopy techniques to measure force transmission, protein-protein binding, and protein activation in and around living cells. These measurements are made at subcellular resolution to understand how molecular processes drive cellular behavior. The goal is to use these quantitative experimental observations to guide the development of multiscale mathematical models to aid in the design of therapeutics for, or diagnosis of, pathologies such as cancer metastasis.

**Brent Shanks** – Our group works on the design and synthesis of heterogeneous catalyst systems for efficient chemical reactions. Reaction systems that are of particular interest are conversions leading to biorenewable chemicals and fuels, which can be used to replace nonrenewable fossil fuel-derived chemicals and fuels. We are interested in the selective removal of oxygen in multi-functional molecules and are evaluating the ability to have sufficiently controlled synthesis of catalytic reaction domains at the nanoscale so as to have molecularly well-defined active sites.

**Jacqueline Shanks** – Our research is specialized in metabolic engineering of plant secondary metabolites and in phytoremediation of explosives. Much of metabolic engineering work has focused on the production of indole alkaloids (secondary metabolites with high pharmaceutical value) in *Catharanthus roseus* hairy root tissue cultures. We have developed quantitative tools (NMR, HPLC, etc.) and methodology in determining the sources of flux limitation in indole alkaloid production. The same plant tissue culture system, *C. roseus* hairy roots, is used as a model system for plant roots in phytoremediation studies. Explosives are widespread and persistent in our environment; plants may be one way to remediate contaminated soil and water. Our research group is determining the metabolic structure and kinetics of the transformation products of trinitrotoluene (TNT) and related nitroaromatic contaminants in plant tissues.

**Zengyi Shao** – My group focuses on designing synthetic biology strategies to enable microbial factories to produce biorenewable chemicals from cheap feedstocks. In addition to *Saccharomyces cerevisiae* and *Escherichia coli*, the two most commonly used microorganisms; we are particularly interested in engineering other non-conventional yeast strains with desired features. For example, *Pichia stipitis* has the highest native ability to ferment xylose, the other major sugar in biomass hydrolysate in addition to glucose; *Issatchenkia orientalis* shows a very strong tolerance of carboxylic acids, which are important precursors used to synthesize a wide variety of compounds. In addition, we are working on constructing microbial consortia to tackle challenges which cannot be easily solved by single organisms. Lastly, we are building various high-throughput optimization approaches to improve strain robustness from a systematic level.

**Jean-Philippe Tessonier** – We are an interdisciplinary group developing sustainable solutions for the production of chemicals and energy from renewable feedstock. Specifically, we design novel heterogeneous catalysts at the nanoscale. Current topics include nanocarbons and hierarchical zeolites.

**R. Dennis Vigil** – Our current research is focused on the development of novel photobioreactors that take advantage of hydrodynamic structures to increase the frequency that phototrophic microorganisms experience light/dark cycles, which in turn increases the rate of photosynthesis and light utilization efficiency. We are also working on developing novel techniques, using seismic waves, to mobilize oil trapped in porous rocks.

**Qun Wang** – We research Biomaterials, Intestinal Engineering, Nanotechnology, and Drug Delivery (BIND) to provide innovative solutions and products for human health including evaluation of absorption efficacy of anticancer drug-loaded nanoparticles in intestines. Oral delivery via gastrointestinal tract is the most common drug administration route. Nanomedicine is an efficient formulation for many diseases, such as inflammatory bowel disease and colorectal cancer. However, no realistic platform to evaluate the absorption efficacy of nanocarriers to intestines exists. Single intestinal stem cells can build crypt-villus structure in vitro has the great potential to fill this gap. Undergraduate student research will contribute substantially to this blank area.

## American Institute of Chemical Engineers (AIChE)

The professional society for chemical engineering is the American Institute of Chemical Engineers (AIChE). Iowa State University has a very active student chapter, which has gained national recognition through recent awards for its program and leadership and awards won in student paper contests at regional meetings. More than one third of the undergraduates in chemical engineering are members of the student chapter.

The objectives of the chapter are to promote the professional development of its members and to contribute to the development of chemical engineering at Iowa State. Membership provides the opportunity to meet other chemical engineering students and the members of the faculty, to learn about the professional experiences of others, and to discuss employment and career possibilities.

Meetings will normally be held in the evening at Sweeney Hall. Event information is made available through a member email list and the ISU AIChE Facebook group. Other activities include attending the regional AIChE conference and participating on the ChemE Car team. Club officers present an update to the department at the CBE Awards Banquet.

The best time to sign up for membership is at the AIChE fall picnic. Membership dues are \$10 per year. If you have any questions about the student chapter, feel free to contact any of the officers listed below. We are looking forward to seeing you at the meetings.

The chapter website is: <http://aiche.cbe.iastate.edu>

The Facebook Group is: <http://facebook/groups/isuaiche>

### **2014-2015 Officers** (net ID's in parentheses preface email address@iastate.edu)

President	Eli Reiser (ecreiser)	Treasurer	Yee Shiean Tan (yshiean)
Vice President	Jill Schoborg (jillms)	Social Chair	Catherine Le Denmat (cathld)
Secretary	Evie Goh (evie0215)	ChemE Car Chair	Chris Isely (cisely)
Outreach Chair	Gavin Hellmich (hellmich)	Faculty Adviser	Stephanie Loveland (prairie)

## National Organization of Black Chemists and Chemical Engineers (NOBCChE)

NOBCChE offers diverse programs designed to foster professional development and encourage students to pursue careers in science and technical fields. Also, the club provides industrial chemical companies with an avenue for better selection of prospective applicants.

Advisers

Derrick Rollins – CH E

Malika Jeffries-EI – CHEM



## Omega Chi Epsilon

Omega Chi Epsilon, Chemical Engineering Honor Society, recognizes and promotes high scholarship, original investigation, and professional service in chemical engineering. The honor society was formed at the University of Illinois in 1931. The Beta Chapter was formed at Iowa State in 1932 and went inactive in 1937. The local chapter was reactivated in 1966. The current national membership includes more than 20,000 men and women from 67 chapters.

To be considered for membership, juniors must have a minimum 3.25 GPA and seniors a minimum 3.00 GPA. Eligible students also must have completed six credits of chemical engineering courses. In addition, members must possess traits of personality and leadership that make them most likely to succeed in their chosen fields. Initiation ceremonies are held during fall semester. The chapter organizes a number of service activities throughout the year, including: hosting student-faculty Friday After Classes (FACs), hosting the department's spring picnic, providing student representatives for departmental committees, and sponsoring the Omega Chi Epsilon Outstanding Senior Award given at the CBE department banquet.

### 2014-2015 Officers (net ID's in parentheses)

President	Josh Anderson (jja)	Treasurer	Christine Leise (caleise)
Vice President	Ali Imran (aimran)	Treasurer-elect:	Pamela Quek (pamela)
Secretary	Sheen Rhu Yeo (rebelle1)	Social Chair	Rachel Lieser (rmlieser)
Adviser	Zengyi Shao (zyshao)		

For further information, please contact Dr. Zengyi Shao, 2033 Sweeney Hall.

## Other Honor Societies

There are a number of other honor societies available to chemical engineering students in addition to Omega Chi Epsilon. Some of them are listed below. Unless otherwise stated, membership is university-wide and available to undergraduates.

Society	Restrictions	Qualities Recognized
Alpha Lambda Delta	Freshmen	Scholarship
Cardinal Key	Seniors	Leadership, service, scholarship
Mortar Board	Juniors	Scholarship, leadership, service
Phi Eta Sigma	Freshmen	Scholarship
Phi Kappa Phi	All-University	Scholarship
Tau Beta Pi	Engineering College	Scholarship, character

## Employment and Scholarship Opportunities

Each year the College of Engineering, through its Scholarships and Awards Committee, offers awards to engineering students. Last year, more than 1,000 students in the college received awards. Various companies, trade associations, and individuals donate these awards. More information is available online at <http://www.engineering.iastate.edu/student-services/scholarships>. These awards are based primarily on academic performance and university involvement. The university Student Financial Aid Office, 0210 Beardshear Hall or <http://www.financialaid.iastate.edu>, handles scholarships based on financial need.

To be considered for a College of Engineering Scholarship, the applicant must have attended Iowa State University for a period of one semester prior to spring semester and must have at least two semesters remaining in which to use the award starting in the fall semester. The number of scholarships available for freshmen is limited so the majority of the awards are made for use during the student's junior or senior years. **Applications must be submitted online and are normally due by February 1.**

For additional information, contact Jane Stowe at 294-9295/jmstowe@iastate.edu  
or Tina Prouty at 294-8678/tnprouty@iastate.edu

## Loans

Students interested in obtaining an education loan should contact the Office of Student Financial Aid, Room 0210 Beardshear Hall. Information about the requirements and arrangements for taking out a loan are best handled directly with personnel from this office.

## Part-Time Employment

In addition to jobs available to students throughout the university, there are many part-time jobs available in CBE. The CBE department seeks research helpers and student assistants.

## Research Helpers

CBE department faculty members employ undergraduate research helpers during the summer, fall, and spring for projects. Ames Laboratory also employs some summer research assistants. Normally these positions require a person with at least a sophomore standing. The work is widely varied since the primary function of the research helper is assisting graduate students with their projects. Typical functions include performing chemical analysis, constructing equipment, taking data, and reducing data. Through this type of work, the student has an opportunity to gain valuable professional experience using modern equipment and research techniques.

## Student Assistants

The CBE department employs eight to 10 students per semester as student assistants to serve primarily as paper graders. Normally the student must be a junior or senior. Aside from providing income, this work gives the assistant a valuable review of basic chemical engineering gained through following the solutions and errors of others.

For additional information, contact DeAnn Pitman in 2162 Sweeney Hall.

## Cooperative (Work-School) Program

The CBE department conducts a cooperative program with a number of chemical processing companies. The program provides an opportunity for students enrolled in chemical engineering to gain practical experience while working toward their B.S. degrees. Co-op work arrangements are with companies located throughout the U.S., but the majority are in Iowa and Minnesota.

The five-year program calls for alternate semesters of school and work experience primarily during the sophomore and junior years. Participating companies make employment offers after conducting interviews with the students. Students need to register with Engineering Career Services to schedule interviews on CyHire, <https://cyhire.iastate.edu/students>.

Advantages of the program are that students:

- ❖ Increase competitive edge for full-time employment
- ❖ Enhance career exploration and clarification of professional goals
- ❖ Develop greater responsibility and self-confidence
- ❖ Improve interpersonal and communication skills
- ❖ Create a process of development, assessment, and continuous professional growth
- ❖ Maintain full-time student status without tuition and fees
- ❖ Reflect work experience on transcript
- ❖ Earn money to cover much of their college expenses
- ❖ Complement classroom learning with practical work experience

Disadvantages include:

- ❖ Loss of continuity in some course sequences because of the periodic interruption of work
- ❖ Possible limitations in participating in some outside activities
- ❖ Lengthening of program

During the year, meetings to describe the co-op program will be sponsored by Engineering Career Services and some companies. Interviews for co-op positions will be scheduled with the participating companies in both the fall and spring semesters. Interested students who have the necessary qualifications should discuss this with their advisor. The co-op advisor, Brenda Kutz, 2162B Sweeney Hall, also is available if you have questions or concerns. The process is explained fully on the Engineering Career Services website (<http://www.engineering.iastate.edu/ecs>). The Student Services Center staff can assist with necessary paperwork.

The following are some of the companies who currently take chemical engineering co-ops from Iowa State University: 3M, Caterpillar, Dow Corning, Equistar, Fisher Rosemount, General Mills, IBM, Intel, and Procter & Gamble.

### **Internships**

During the freshman and sophomore years, intern opportunities in industry are limited so the best employment opportunity for students is normally in their local community. After the sophomore year, more internships become available for either fall or spring terms. Information is posted on the Engineering Career Services webpage (<http://www.engineering.iastate.edu/ecs>). The Fall and Spring Engineering Career Fairs are excellent opportunities to pursue job opportunities. The Student Services Center staff can assist with necessary paperwork.

An industrial work experience is an excellent opportunity for students to observe first-hand the type of positions held by chemical engineers. Some students return to their employer for permanent employment after graduation; however, neither the employer nor employee is under any obligation to extend the work experience to permanent employment.

There are many opportunities for summer work with various governmental agencies, both state and federal. Since many of these agencies do not recruit on campus, Engineering Career Services maintains an up-to-date file of opportunities on its website (<http://engineering.iastate.edu/ecs>).

Students gain experience in the applications of the principles studied in the classroom, which will make subsequent coursework more meaningful.

### **Process for Relevant Work Experiences**

1. Students must print out and complete the Employment Acceptance Form found on this website: <http://www.engineering.iastate.edu/ecs/internships/how-to-register>
2. Meet with your academic adviser to discuss eligibility, possible impacts on your plan of study, and to obtain the required signature for verification.
3. The form is then returned to Engineering Career Services. The student will be provided the appropriate course reference number for registration. Engineering Career Services encourages all students who participate in relevant work experiences to register the experience with their office. Among other benefits, this opportunity allows students to maintain full-time student status without incurring tuition or fees. The work experience is registered as a Satisfactory/Fail course and requires the student to take additional responsibilities about their learning outcomes and performance. Be sure to look at the Course Syllabus (<http://www.engineering.iastate.edu/ecs/internships/how-to-register>). The Course Syllabus provides all of the deadlines, forms, and information that you need to know and complete to earn an "S" for the work experience.

## **Part 4: Preparing for the Future**

## Permanent Employment

By your last year, you should have a career objective in mind. You are encouraged to set up a CyHire account and utilize the many resources available to you: <http://www.cyhire.iastate.edu/students>. View companies who are recruiting and hiring qualified students and identify the companies that you feel most closely meet your career objectives and values. You should try to learn as much about these companies as you can. You can use *The Thomas Register of American Manufacturers* or *Moody's Manuals*, available company literature located in the Engineering Career Services Office, and links to companies available in CyHire.

Do not overlook state and federal agencies when seeking permanent employment. The various pollution control and environmental protection agencies, for example, offer unique opportunities for chemical engineering graduates.

Throughout the academic year, Engineering Career Services offers seminars on the interviewing process. Take full advantage of the services offered by this office; they are experts in the placement process. View a list of the current Engineering Career Services Career Development Seminars and Workshops at <http://www.engineering.iastate.edu/ecs/careerdevelopmentworkshops>. Feel free to discuss with them interviewing problems that you may encounter. Get all the help you can in selling yourself to the interviewer. Start interviewing as soon as possible in the fall. You will gain confidence with experience. Download presentations and handouts anytime at the Career Development Seminars and Workshops webpage.

Arrange on-site interviews so that you miss as few classes as possible. Of course, you are expected to inform your instructors of travel plans before you leave and to make up all assignments. Many of your interviews can be scheduled between semesters.

When you seek employment, it is common practice for prospective employers to ask you for faculty references. It is expected that you will contact the faculty member before you give his or her name as a reference. Make sure that references you choose know something positive about you. Provide references with a copy of your resume. Questions typically found on reference requests include the following:

- ❖ Does the student finish assignments on time?
- ❖ Do the assignments show evidence of extra thought or effort?
- ❖ How does the student react to criticism?
- ❖ What is the student's attitude toward safety practices?

## Graduate Study in Chemical and Biological Engineering

Chemical engineering students frequently discover that there is much to be learned about chemical engineering beyond what is taught in the undergraduate courses. Part of the purpose of graduate study (M.Engr., M.S., and Ph.D.) is to further develop the fundamental theories presented at the undergraduate level; many ISU students pursue graduate work for this reason.

An equally important purpose is to give the student an opportunity to plan, undertake, analyze, and report on an independent research project. Graduate study also may qualify the student for employment opportunities that require more technical knowledge and research experience than what is acquired at the undergraduate level.

A comprehensive resource for students thinking about going to graduate school is available at <http://www.gradschools.com>. This website has information about various schools and about the Graduate Record Examination (GRE), along with other valuable information. A different website that has more detailed information specifically about chemical engineering graduate programs in the country is maintained by the Council for Chemical Research at <http://www.ccrhq.org>. Students interested in pursuing graduate studies in Biomedical Engineering should refer to <http://www.whitaker.org>.

Students thinking about pursuing graduate studies should try to become involved in undergraduate research. At Iowa State, research credits can be earned through CH E 490 or CH E 490H. Up to six credits of independent study or research can be used towards their professional, engineering, or CH E elective

requirements. Summer research opportunities are also available at Iowa State. Students interested in pursuing summer research opportunities at other schools should visit [http://www.nsf.gov/crssprgm/reu/reu\\_search.cfm](http://www.nsf.gov/crssprgm/reu/reu_search.cfm) for a list of the National Science Foundation Research Experience for Undergraduates sites.

Research and teaching assistantships or fellowships are widely available to qualified students for graduate study in chemical engineering. Typical PhD stipends at Iowa State provide more than \$2,300 per month in addition to tuition. There also are several competitive fellowships such as the National Science Foundation, the Tau Beta Pi, and other graduate fellowships for which students may apply.

Application forms for admission to graduate study at Iowa State are available at <http://www.admissions.iastate.edu/graduate/index.php>. The application deadlines are February 1 for the fall semester and October 1 for the spring semester. A list of current research areas of the CBE faculty at Iowa State is also available on the CBE website at <http://www.cbe.iastate.edu/research/>.

## **Preparation for Non-Engineering Graduate Study**

Chemical engineering graduates are favorably received by medical, law, and business schools. Some planning is required to ensure that you have taken the courses required by admissions committees for those programs. In addition to reading the information below, students interested in law or medicine should visit with LAS Pre-professional advisers in Catt Hall (<http://www.las.iastate.edu/pre-health> or <http://www.las.iastate.edu/pre-law>). Students interested in a MBA should visit with the Business Graduate Program Office in the Gerdin Business Building (<http://www.business.iastate.edu/masters/mba>).

### **Medical School**

General requirements (in addition to the normal chemical engineering requirements) include:  
Organic Chemistry Laboratories - CHEM 331L, CHEM 332L, 1 cr. each, and  
Principles of Biology - BIOL 211 (3), BIOL 211L (1), BIOL 212 (3), and BIOL 212L (1).

One 300-level biology course; e.g., BIOL 313 (3), BIOL 314 (3), BIOL 335 (4), BIOL 351 (5), or BIOL 423 (3); is required by the University of Iowa College of Medicine.

Some of these courses may be used to satisfy the Professional Elective requirement. Additional relevant courses that would apply to the technical elective requirements are the biologically-related chemical engineering courses such as CH E 415, CH E 427, CH E 440, or CH E 562.

Note that you may need to begin taking these courses earlier in your program than as the Professional Electives are indicated on our flow chart.

### **Business School (MBA)**

Most MBA programs are set up to take students coming from non-business programs and have no specific requirements. However, such courses as ECON 101 and ECON 102, which fulfill SSH elective requirements, as well as a course in statistics, which may count as a Statistical Elective, are highly recommended. Courses in accounting, management, or finance would provide a head start and can be taken as extra electives, which would not count towards a B.S. chemical engineering degree.

### **Law School**

Law schools generally have no specific course requirements, but do look for courses where the student would have had writing and speaking experience, particularly where the topic required critical appraisal of material. Such courses often may be used as SSH electives. For example, students have found that PHIL 206, Introduction to Logic and Scientific Reasoning, is helpful in preparing for the Law School Admissions Test (LSAT).