

IOWA STATE UNIVERSITY

Department of Chemical and Biological Engineering

Undergraduate Student Booklet

2020-2021 Catalog

che-advising@iastate.edu

<http://www.cbe.iastate.edu/current-students/guides-and-handbooks>

Table of Contents

Welcome Letter	iv
Introduction.....	1
Part 1: General Information	2
The Profession of Chemical Engineering	3
Chemical and Biological Engineering Facilities.....	3
Release of Student Information.....	3
Advising.....	4
Academic Integrity.....	4
American Institute of Chemical Engineers (AIChE) Code of Ethics	5
Part 2: Curriculum and Requirements.....	6
Outcomes of the Program	7
Basic Program Requirements	7
Core Course Requirements.....	7
Biochemistry Requirement	8
Social Science and Humanities (SSH) Electives.....	8
U.S. Diversity (US Div) and International Perspectives (IP) Requirements	8
U ST 110: IFYE Seminar.....	9
Approved Social Science and Humanities Course List	10
Completing your Plan of Study (POS).....	13
Plan of Study Form	14
Chemical Engineering Flowchart	15
Undergraduate Curriculum in Chemical Engineering	16
Electives	17
Table I – Electives	17
ChE Electives Availability	18
Suggested Emphases for Technical Electives	19
General Graduate School Preparation	19
General Industrial Preparation.....	19
Biochemical Engineering	19
Biomedical Engineering.....	20
Environmental Science and Engineering.....	20
Food Engineering	20
Materials Science	20
Biomedical Engineering Minor.....	21
Policies	22
Transfer Credits.....	22
Academic Warning or Probation.....	22
English Proficiency Requirement.....	22
Chem 201/201L Policy.....	22
Graduation Requirements.....	22
Pass-Not Pass Policy	23
Prerequisites and Co-requisites.....	23
Part 3: Opportunities for Undergraduates	24
International Studies in Chemical and Biological Engineering	25
University of Oviedo Summer Laboratory Program.....	25
International University Exchanges	25
Honors Program.....	26
Undergraduate Research Program and Independent Study	26
American Institute of Chemical Engineers (AIChE).....	27
National Organization for the Professional Advancement of Black Chemists and Chemical Engineers (NOBCChE).....	27
Omega Chi Epsilon	27
Other Honor Societies.....	28
Employment and Scholarship Opportunities	28
Co-ops and Internships	28

Dear Undergraduate Students:

Welcome to Iowa State University. We are delighted to have you join Cyclone Nation as a student in the Department of Chemical and Biological Engineering (CBE).

As a CBE undergraduate, you will be part of a diverse and vibrant department with over 100 years of excellence in engineering education. We provide a supportive and stimulating environment that combines talented students, a diverse faculty, excellent facilities and a rich research and teaching tradition. Graduates from our department have gone on to do great things while pursuing careers in the chemical industry, pharmaceuticals, food production, microelectronics, health care, law, academics, and many others.

Thank you for “choosing your adventure” at Iowa State. We encourage you to explore our student organizations, undergraduate research opportunities, study abroad programs, and more.

Welcome to CBE. We strive to make your college experience enjoyable and rewarding.

Go Cyclones,



Andrew C. Hillier
Professor and Reginald R. Baxter Endowed Department Chair
Department of Chemical and Biological Engineering

Introduction

This booklet has been prepared to help you plan your program in chemical engineering at Iowa State University and is intended to guide you through the chemical engineering curriculum, to describe various opportunities and options, and to relay important policies and procedures. Other information sources are:

- ❖ Academic Departments at ISU
<http://www.iastate.edu/depts>
- ❖ College of Engineering
<http://www.engineering.iastate.edu>
- ❖ Course Equivalency Guide
<http://www.admissions.iastate.edu/equiv/index.php>
- ❖ Department of Chemical and Biological Engineering
<http://www.cbe.iastate.edu>
- ❖ Experimental (###X) Course Descriptions
<http://www.registrar.iastate.edu/faculty-staff/courses/explisting>
- ❖ General Catalog (curriculum and course information)
<http://catalog.iastate.edu>
- ❖ ISU Information Handbook (academic regulations)
<http://policy.iastate.edu>
- ❖ ISU Academic Calendar
<http://www.registrar.iastate.edu/calendar>
- ❖ ISU Academic Information Technologies
<http://www.it.iastate.edu>
- ❖ ISU Registrar Forms
<http://www.registrar.iastate.edu/forms>
- ❖ Pre-Health Information
<http://www.las.iastate.edu/pre-health>
- ❖ Pre-Law Information
<http://www.las.iastate.edu/pre-law>
- ❖ Schedule of Classes
<http://classes.iastate.edu>
- ❖ Scholarship Information
<http://www.financialaid.iastate.edu>
<http://www.engineering.iastate.edu/student-services/scholarships>
<http://www.fastweb.com>
- ❖ Student Answer Center
<http://financialaid.iastate.edu/sac>
- ❖ Student Organizations
<http://sodb.stuorg.iastate.edu>
- ❖ Tuition and Fees
<http://www.registrar.iastate.edu/fees>
- ❖ Writing and Media Center
<http://new.dso.iastate.edu/wmc>

Part 1: General Information

The Profession of Chemical Engineering

Chemical engineering is an exciting and diverse profession with a tremendous range of occupations and opportunities. Chemical engineers have always been proud of their flexibility. A solid and very general technical background enables them to work effectively in and adapt quickly to many different fields.

The chemical engineer is an expert at dealing with the chemical and physical changes of matter and with the conversion of energy. Most chemical engineers use this knowledge in jobs that involve the application of chemical research to the production of chemical materials and products. This entails product development and market research; economic feasibility studies; research; development and design of chemical processes; design of process equipment; supervision of the construction, start-up, operation, and maintenance of chemical plants; and process improvement for pollution control and energy conservation.

Chemical engineers are employed in a wide variety of industries: petroleum and gas, chemicals, minerals and metals; glass and ceramics; plastics and resins; soap and detergents; cosmetics; rubber and tire; food production; fertilizer and agricultural chemicals; nuclear energy; photographic products; microchip manufacturing; missile and space; synthetic fibers and textiles; paint, paper, and cellulose; pharmaceuticals; and process equipment manufacture. Additionally, chemical engineers are involved in areas such as private consulting, government, higher education, applied physics, manufacturing, applied mathematics, biochemistry, medicine, patent law, food processing, pollution monitoring and prediction, sales, and industrial management. All of these are in addition to the already wide range of types of jobs traditionally thought of as chemical engineering jobs.

Chemical and Biological Engineering Facilities

Sweeney Hall houses classrooms, computer laboratories, research and teaching laboratories, and departmental and staff offices.

Department Administration

The department office and the office of the Department Chair are located in 2114 Sweeney Hall. The department office telephone number is 515-294-7642. The Mike and Jean Steffenson Student Services Center is located in 2162 Sweeney Hall; the telephone number is 515-294-7643.

Undergraduate Student Lounge

You have a place to study in 0107 Sweeney. Comfortable seating, tables with chairs, a phone, and several computers are available in this room. The code to unlock the door can be requested from the staff in 2162 Sweeney Hall.

Computer Labs and Work Spaces

The Department of Chemical and Biological Engineering has a growing list of computer resources available to undergraduate students. The department has several computer labs devoted to undergraduate student use. Rooms 0104, 1123, and 1150 Sweeney Hall are open to all chemical engineering students. Additionally, 3149 Sweeney Hall is a laptop computer lab that is available when not in use by a class. 2123 Sweeney Hall is also available as a collaborative space for students. Other labs across campus also offer computers for general use. Students can search for a computer lab based on operating system, software, hours when available, etc. at <https://it.engineering.iastate.edu/labs/>.

Release of Student Information

The department routinely receives requests from graduate schools to provide names of potential candidates to aid them in their recruitment. We will provide such lists using directory information, unless you request that we not include you in such releases. We do not release individual GPA information unless the student has authorized the organization to request it. You may request exclusion by setting your information release preferences in AccessPlus.

Advising

Our Mission

Academic advising is an intentional, collaborative relationship based on trust and mutual respect. This relationship promotes the student's development of competence, autonomy, and sound decision-making skills. The goal of academic advising is an individualized academic experience for each student developed through a mentoring relationship.

The primary point of contact for most advising questions will be your academic adviser. The academic advising staff will help you with the class registration process; Degree Audit corrections; answering questions about ISU, the College of Engineering, and departmental policies and procedures; handling class scheduling difficulties, and guiding you to campus resources. While your adviser will provide your Registration Access Number (RAN) via email, it is highly recommended that you meet with your adviser each semester to get guidance regarding class registration and to help you stay on track towards completing your degree. See the ISU Academic Calendar for registration advising dates.

You will be assigned a faculty mentor in ENGR 101, and you will complete your Plan of Study with assistance from your faculty mentor in CH E 202. Visit with your faculty mentor to discuss progress and goals, select electives that support your plan of study, generate career goals, learn more about the profession of chemical engineering, gain assistance in applying to graduate school, and for any other issue that requires faculty expertise.

You are expected to plan your POS for a more intentional college experience. Degree Audits show your progress toward completing degree requirements and are available in AccessPlus at any time to you or your academic adviser.

See your faculty mentor for:

Developing an elective package
Information about the profession
Career and profession questions
Working on a plan of study
Discussing undergraduate independent study projects
Obtaining a recommendation letter
Learning about graduate school

See your adviser for:

Registering for courses
Adding or dropping a course
Information about degree requirements
Resolving course scheduling problems
Registering a co-op or internship
Providing copies of forms and department publications
Guidance to campus and community resources

Academic Integrity

It is imperative that society be able to rely upon the integrity of the members of our profession. At the university, faculty members expect you to follow high ethical standards in your academic work. Rules and procedures regarding actions that constitute academic dishonesty are included in the Iowa State University Information Handbook. These apply to all students. In addition, the chemical engineering faculty have adopted the following policy statement, which applies in chemical engineering courses.

Faculty members expect that work submitted in your name be entirely your own work. You should not copy assignments, exams, quizzes, computer programs, etc. from others or allow copying of your work. It is usually permissible to discuss homework assignments with other students, unless your instructor specifies to the contrary. For examinations and quizzes, a stricter standard is imposed. For exams and quizzes the presumption, unless otherwise stated, is no discussion, no use of notes, no use of books or journals, and no use of work of others. If in a particular instance the instructor wishes to modify any part of the department's policy, you will be so informed in writing.

Please refer to the Dean of Students Office's Academic Misconduct policy at the following link:
<https://www.studentconduct.dso.iastate.edu/academic-misconduct/armstu>

American Institute of Chemical Engineers (AIChE) Code of Ethics

Members of the American Institute of Chemical Engineers shall uphold and advance the integrity, honor, and dignity of the engineering profession by: being honest and impartial and serving with fidelity their employers, their clients, and the public; striving to increase the competence and prestige of the engineering profession; and using their knowledge and skill for the enhancement of human welfare. To achieve these goals, members shall:

- ❖ Hold paramount the safety, health and welfare of the public and protect the environment in performance of their professional duties
- ❖ Formally advise their employers or clients (and consider further disclosure, if warranted) if they perceive that a consequence of their duties will adversely affect the present or future health or safety of their colleagues or the public
- ❖ Accept responsibility for their actions, seek and heed critical review of their work and offer objective criticism of the work of others
- ❖ Issue statements or present information only in an objective and truthful manner
- ❖ Act in professional matters for each employer or client as faithful agents or trustees, avoiding conflicts of interest and never breaching confidentiality
- ❖ Treat all colleagues and co-workers fairly and respectfully, recognizing their unique contributions and capabilities
- ❖ Perform professional services only in areas of their competence
- ❖ Build their professional reputations on the merits of their services
- ❖ Continue their professional development throughout their careers, and provide opportunities for the professional development of those under their supervision
- ❖ Never tolerate harassment
- ❖ Conduct themselves in a fair, honorable, and respectful manner

Part 2: Curriculum and Requirements

Outcomes of the Program

The chemical engineering program should produce graduates that have:

- ◆ an ability to identify, formulate, and solve complex engineering problems by applying principles of engineering, science, and mathematics
- ◆ an ability to apply engineering design to produce solutions that meet specified needs with consideration of public health, safety, and welfare, as well as global, cultural, social, environmental, and economic factors
- ◆ an ability to communicate effectively with a range of audiences
- ◆ an ability to recognize ethical and professional responsibilities in engineering situations and make informed judgments, which must consider the impact of engineering solutions in global, economic, environmental, and societal contexts
- ◆ an ability to function effectively on a team whose members together provide leadership, create a collaborative and inclusive environment, establish goals, plan tasks, and meet objectives
- ◆ an ability to develop and conduct appropriate experimentation, analyze and interpret data, and use engineering judgment to draw conclusions
- ◆ an ability to acquire and apply new knowledge as needed, using appropriate learning strategies

Basic Program Requirements

The Basic Program is a set of courses that provides a foundation common to all engineering curricula. Students normally enroll in most of the Basic Program courses during their first year. Before enrolling in engineering courses at the 200-level and above, students enrolled in the College of Engineering must do the following:

1. Complete the Basic Program with a Basic Program grade point average (GPA) of at least 2.00.
2. Earn an ISU cumulative GPA of at least 2.00.

A grade of C or better is required for any transfer credit course applied to the Basic Program. Grades from transfer courses will not be used in computing the Basic Program GPA. The basic program courses are:

MATH 165, MATH 166
ENGL 150
ENGR 101, CH E 160

CHEM 177 (or CHEM 167)
PHYS 221
LIB 160

See the [Basic Program for Engineering Curricula](http://catalog.iastate.edu/collegeofengineering/#basicprogramcurriculertext) in the ISU Catalog for a full description of requirements and exceptions (<http://catalog.iastate.edu/collegeofengineering/#basicprogramcurriculertext>).

Please note:

1. It may be possible to substitute transfer credit for CH E 160 if the coursework contains both engineering problem-solving and computer programming experience.
2. CHEM 167 can substitute for CHEM 177; see your adviser for successful transition into CHEM 178.
3. See the ISUComm Foundation webpage for more information on English placement:
<http://www.engl.iastate.edu/isucomm/foundation-2/placement-engl-150/>.

Core Course Requirement

The College of Engineering requires that each student must have a minimum GPA of 2.00 in a group of 200-level and above courses to meet graduation requirements. The chemical engineering faculty have designated the following chemical engineering courses as core courses for this requirement: CH E 202, CH E 210, CH E 310, CH E 325, CH E 356, CH E 357, CH E 358, CH E 381, CH E 382, CH E 420, CH E 421, CH E 426, and CH E 430. The Degree Audit available in AccessPlus will show this grade point average each semester under Chemical Engineering Core. Transfer credits will not be included in this average. The cumulative GPA is based upon all courses, excluding transfer courses. This means the grade point average will be based upon those courses that were actually taken at Iowa State University.

Biochemistry Requirement

Chemical engineering students have several options to complete the biochemistry requirement. The CBE department asks students to think about which course will best fit their needs.

BBMB 303	One semester survey of biochemistry; presents applications of biochemistry in the areas of biochemical engineering. Only offered during fall semesters.
BBMB 404 & BBMB 405	Two semester biochemistry sequence; students who are interested in pursuing a graduate degree or pre-health program are encouraged to take BBMB 404 and 405. BBMB 404 satisfies the biochemistry requirement, while BBMB 405 satisfies the advanced chemistry elective or the professional elective.

Social Science and Humanities (SSH) Electives

Both Iowa State University and industry want our graduates to be well-rounded professionals who can interact with their coworkers, business clients, and society. Social Science and Humanities (SSH) electives are an important part of your chemical engineering degree program. These courses can help you develop or expand skills necessary to achieve success within both industry and society. *The CBE department defines SSH electives as non-technical, non-skilled based courses that help students to develop a love for lifelong learning, foster critical thinking, and expand their worldview.* An approved list of SSH electives is listed on pages 10 - 12.

Using Independent Study (490) courses as SSH electives requires **prior** approval by your adviser and the CBE Curriculum Committee. Consult with your adviser for courses not on the SSH list, such as Honors Seminars, experimental courses (<http://www.registrar.iastate.edu/faculty-staff/courses/explisting>), or other courses that you think might qualify.

SSH requirements include:

- Minimum of 15 credits from the list of approved courses
- At least 6, but no more than 9, credits must be in the same department

U.S. Diversity (US Div) and International Perspectives (IP) Requirements

A similar Iowa State University and CBE department goal is to prepare you to meet the challenges of responsible citizenship and effective professional roles in a culturally diverse global community. To help achieve this goal, all undergraduate students must fulfill graduation requirements in two areas: U.S. Diversity (US Div) and International Perspectives (IP). The focus of the US Div requirement is the multicultural society of the United States. Courses used to meet the requirement provide students with insights that enhance their understanding of diversity among people in the U.S. The focus of the IP requirement is the global community. Its objective is to promote your understanding of cultural diversity and interdependence on a global scale.

Many approved SSH electives also fulfill either the US Div or IP requirement. The list of approved SSH electives (see pages 10 -12) has notations if a course meets the US Div or IP requirement. For a more complete listing of US Div and IP courses, refer to the following webpages:

- US Div Course Listing: <http://www.registrar.iastate.edu/students/div-ip-guide/usdiversity-courses>
- IP Course Listing: <http://www.registrar.iastate.edu/students/div-ip-guide/IntlPerspectives-current>

The IP requirement may be alternatively fulfilled by completing one of the following:

- An international work experience (e.g. co-op or internship) involving a stay in a foreign country of three weeks or greater in duration.
- An approved study abroad experience involving a stay in a foreign country of three weeks or greater in duration.
- An approved study abroad experience that is three or more credits.

Note: International students are exempt from the IP requirement.

U ST 110: IFYE Seminar

International students need to successfully complete the International First Year Experience (IFYE) Seminar. The IFYE Seminar aims to help international students transition into their educational experience in the United States. The seminar covers academic culture, classroom culture, campus and community resources, learning styles, study skills, basic immigration status and employment benefits, student health and wellness, and research and presentation skills. IFYE is offered on a satisfactory-fail basis only.

Approved Social Science and Humanities Course List

Dept	Course #	US Div	Int'l Persp
A M D Apparel, Merchandising & Design			
	165	X	
	257		
	354		X
	356		
	362		X
	372		X
	467		
ACCT Accounting			
	215		
AESHM Apparel/Events/Hospitality Mgmt			
	342	X	
	421		X
AF AM African American Studies			
<i>All AF AM courses except 490 can be SSH</i>			
	201	X	
	311		X
	325		X
	330	X	
	334	X	
	347	X	
	350	X	
	353	X	
	354	X	
	460	X	
	473	X	
AGRON Agronomy			
	342		X
	450		
AM IN American Indian Studies			
<i>All AM IN courses except 490 can be SSH</i>			
	210	X	
	240	X	
	310	X	
	315	X	
	320	X	
	322	X	
	332	X	
	346	X	
	426	X	
ANTHR Anthropology			
	201		X
	202		
	220		X
	230		X
	306		X
	307		
	308		
	309		X
	313		X
	315	X	
	320	X	
	321		
	322	X	
	323*		
	332	X	
	333	X	
	336		X
	340		X

Dept	Course #	US Div	Int'l Persp
ANTHR cont.			
	411		X
	418		X
	444		X
	450		
ARCH Architecture			
	221		X
	321	X	
	322		X
	420	X	
	422		X
	423		X
	424		
	425		
	426	X	
	427		X
ARTGR Art & Graphic Design			
	388	X	
ART H Art History			
<i>All ART H courses except 490 can be SSH</i>			
	280		X
	281		X
	292	X	
	382		X
	384		X
	386	X	
	395	X	
	492		X
	494	X	
BIOL Biology			
	173		
	201		
	307	X	
CH E Chemical Engineering			
	391		X
CL ST Classical Studies			
<i>All CL ST courses except 480, 490 can be SSH</i>			
	273		X
	275		X
	353		X
	372		X
	373		X
	374		X
	376		X
	384		X
	394		X
CMDIS Communication Disorders			
	286	X	
COMST Communication Studies			
	310		X

Dept	Course #	US Div	Int'l Persp
C R P Community & Regional Planning			
	201	X	
	291		X
	293		
	376		
	417		
	484		
	491		
CJ ST Criminal Justice Studies			
	240		
	241		
	320		
	332		
	340		
	341		
	351		
	352		
	402		
	403		
DANCE Dance			
	270		X
	360		
DSN S Design Studies			
	183		
ECON Economics			
	101		
	102		
	301		
	302		
	320		X
	321	X	
	344		
	353		
	355		X
	362		
	376		
	378	X	
	380		
	385		X
	455		X
	480		

Dept	Course #	US Div	Int'l Persp
ENGR Engineering			
	320		X
	327		
ENGL English			
	201		
	219		
	225		
	226		
	227		
	228		
	237		
	240	X	
	260		
	275		
	330		
335 - 396 inclusive (all count as SSH)			
	340	X	
	344	X	
	345	X	
	346	X	
	347	X	
	349	X	
	352	X	
	353		X
	354		X
	370		X
	375		X
	376		X
	389		X
	420		
	422	X	
	440		
	441		
	445		
	450		
	460		

* Check the International Perspectives list for the lettered versions of ANTHR 323:
<http://www.registrar.iastate.edu/students/div-ip-guide/IntlPerspectives-current>

Dept	Course #	US Div	Int'l Persp
ENV S Environmental Studies			
	120		
	160		X
	173		
	201		
	220		X
	293		
	320		
	334		
	342		X
	345		X
	355		
	363		
	380		
	382		
	383		
	384		X
	442		
	450		
	460		
	484		
	491		
FS HN Food Science & Human Nutrition			
	342		X
GERON Gerontology			
	373		
	377	X	
	378	X	
HIST History			
<i>All HIST courses except 490 & 495 can be SSH</i>			
	201		X
	202		X
	207		X
	225	X	
	280		X
	281		X
	284		X
	311		X
	333	X	
	336		X
	337		X
	338		X
	341		X
	353	X	
	354	X	
	374		X
	380	X	
	383		X
	384		X
	386	X	
	389		X
	390		X
	421		X
	422		X

Dept	Course #	US Div	Int'l Persp
HIST cont.			
	442		X
	473	X	
HSP M Hospitality Management			
	260		X
HD FS Human Development & Family Studies			
	102		
	227		
	239	X	
	240	X	
	249	X	
	270	X	
	276	X	
	367		
	373		
	377	X	
	378	X	
	479		
H SCI Human Sciences			
	150	X	
INTST International Studies			
	235		X
	430		X
JL MC Journalism & Mass Communication			
	101		
	401		
	460		
	461		
	462		
	464		
	474		X
	476		X
	477	X	
L A Landscape Architecture			
	272	X	
	274	X	
	371		
	373		X
LD ST Leadership Studies			
	322	X	

Dept	Course #	US Div	Int'l Persp
LING Linguistics			
	119		X
	219		
	286	X	
	305		
	309		X
	413		
	420		
	422	X	
	463		X
MGMT Management			
	370		
	371		
	414		
	471		
	472	X	
MAT E Materials Engineering			
	220		X
	391	X	
M E Mechanical Engineering			
	220		X
	484		X
MUSIC Music			
	102		X
	302		
	304	X	
	383		X
	384		X
	472	X	
	473		
	475		
	476		
PHIL Philosophy			
<i>All PHIL courses except 207 & 490 can be SSH</i>			
	235	X	
	338	X	
POL S Political Science			
<i>All POL S courses except 301, 475, & 490 can be SSH</i>			
	241		X
	251		X
	315		X
	333	X	
	342		X
	349		X
	350		X
	354		X
	385	X	
	452		X

Dept	Course #	US Div	Int'l Persp
PSYCH Psychology			
	101		
	230		
	280		
	310		
	313		
	314		
	346	X	
	347	X	
	348		
	360		
	380		
	381		
	383		
	413		
	450		
	460		
	484		
	488		X
RELIG Religious Studies			
<i>All RELIG courses except 490 & 499 can be SSH</i>			
	205		X
	210	X	
	242		X
	334	X	
	336	X	
	340		X
	342	X	
	352		X
	358		X
	380	X	
	384		X
SOC Sociology			
<i>All SOC courses beyond 130 except 202, 302, 412, 460, 464, & 490 can be SSH</i>			
	220		X
	235	X	
	327	X	
	328	X	
	330	X	
	331	X	
	332	X	
	345		X
	348		X
	411		X
SP CM Speech Communication			
	212		
	216	X	
	275		
	305		
	312		
	323	X	
	350		
	417		

Dept	Course #	US Div	Int'l Persp
THTRE Theatre			
	106		
	110		
	465		
	466		
U ST University Studies			
	321	X	
US LS US Latino/a Studies			
	211	X	
	323*		X
	342	X	
	343		X
	347	X	
	371	X	
	372	X	
	473	X	
W G S Women's and Gender Studies			
<i>All WGS except 258, 490, 491 & 499 can be SSH</i>			
	160	X	
	201	X	
	203	X	
	205	X	
	301		X
	307	X	
	321	X	
	323	X	
	325	X	
	327	X	
	328	X	
	333	X	
	336	X	
	338	X	
	340	X	
	345	X	
	346	X	
	350	X	
	352	X	
	370		X
	374		X
	380	X	
	385	X	
	386	X	
	422	X	
	444		X
	494	X	

Dept	Course #	US Div	Int'l Persp
W LC World Languages and Cultures			
<i>All WLC courses except 490, 491, & 499 for all curricula can be SSH. NOTE: Students may not use grammar, conversational, or composition courses in the native language.</i>			
	WLC 119		X
	WLC 270		X
	WLC 484		X
ARABC Arabic			
	101		
	102		X
	201		X
	202		X
ASL American Sign Language			
	101	X	
	102	X	
	275	X	
CHIN Chinese			
	101		
	102		X
	201		X
	202		X
	272		X
	301		X
	302		X
	304		X
	370		X
	375		X
FRNCH French			
	101		
	102		X
	201		X
	202		X
	301		X
	302		X
	304		X
	305		X
	320		X
	326		X
	340		X
	370		X
	378		X
	476		X

Dept	Course #	US Div	Int'l Persp
GER German			
	101		
	102		X
	201		X
	202		X
	301		X
	302		X
	304		X
	305		X
	320		X
	330		X
	370		X
	371		X
	375		X
	378		X
	395		X
	476		X
GREEK Greek			
	101		
	102		X
LATIN Latin			
	101		
	102		X
	201		X
	332		X

Dept	Course #	US Div	Int'l Persp
RUS Russian			
	101		
	102		X
	201		X
	202		X
	301		X
	304		X
	314		X
	370		X
	375		X
	378		X
	395		X
SPAN Spanish			
	101		
	102		X
	195		X
	201		X
	202		X
	295		X
	303		X
	304		X
	314		X
	321		X
	322		X
	323		X
	324		X
	326		X
	330		X
	332		X
	351		X
	352		X
	354		X
	370		X
	395		X
	401		X
	440		X
	441		X
	445		X
	462		
	463		X

* Check the International Perspectives list for the lettered versions of US LS 323:
<http://www.registrar.iastate.edu/students/div-ip-guide/IntlPerspectives-current>

Completing your Plan of Study (POS)

The purpose of planning your chemical engineering degree is to allow you to determine what courses/programs/activities will help you meet your goals in a timely manner.

On the chemical engineering flowchart (p. 15), cross off courses that you already have completed and circle the courses in which you are currently enrolled. Complete the Plan of Study (POS) form (p. 14) by following the steps below:

1. Completely fill out the heading.
2. List credits that can be used to meet degree requirements that were earned before entering ISU (transfer, AP, test out, etc.) in the box marked transfer courses. List these courses as they would show up in your degree audit or their ISU equivalent. If you are not familiar with how they transfer utilize TRANSIT (<https://transit.iastate.edu/>) and/or your degree audit.
3. Next, choose the semester block that represents your first term at ISU (fall, spring or summer). Label it with the appropriate year (e.g., “2017” for Fall 2017; “2018” for Spring 2018; etc.). List all courses taken that term. Do this for each term through the current term.
4. Continue listing courses that you plan to take for future terms, checking off each course on your flowchart or degree audit as you list it on the POS form. This will help you to account for each requirement without listing the requirement more than once.
5. List each elective course on the right column under the requirement that it will meet. Do this as you list the course in the term that you plan to take it.
6. Keep in mind/make sure:
 - A. Courses are available during the term that you have planned for them. A good resource for this is the Schedule of Classes (<https://classes.iastate.edu/>) or the ISU Course Catalog (<http://catalog.iastate.edu/>).
 - B. Credit loads for each semester are within acceptable limits (≤ 18 credits per semester, or ≤ 21 for Honors Program).
 - C. All course prerequisites are satisfied (the Schedule of Classes and ISU Course Catalog are also helpful to check pre-requisites).
 - D. All curriculum requirements for graduation are satisfied.
 - E. If you are declaring a second major/degree or minor that all courses are accounted for.
7. Discuss your POS with your faculty mentor.

CHEMICAL ENGINEERING CURRICULUM PLAN OF STUDY

Name _____ ID# _____ Entry Term _____ GRAD TERM _____ Date _____

Catalog _____ Honors Double Degree w/ _____ Double Major w/ _____ Minor in _____

Start with transfer courses, fill in the courses prior to ISU, have taken, currently taking, and plan to take that apply to the ChE program. Type in the year following each semester, ex: FALL 2019

- Make sure:
1. Courses are available in the term that you plan for them (e.g., BBMB 303 is fall-only).
 2. All course prerequisites and all curriculum requirements for graduation are satisfied.
 3. All SSH Electives and Technical Electives are correctly satisfied.

Transfer Courses

_____	_____	_____	_____	_____	_____
-------	-------	-------	-------	-------	-------

FALL	CR	SPRING	CR	SUMMER	CR
_____	_____	_____	_____	_____	_____
_____	_____	_____	_____	_____	_____
_____	_____	_____	_____	_____	_____
_____	_____	_____	_____	_____	_____
_____	_____	_____	_____	_____	_____
_____	_____	_____	_____	_____	_____
Total	0	Total	0	Total	0

FALL	CR	SPRING	CR	SUMMER	CR
_____	_____	_____	_____	_____	_____
_____	_____	_____	_____	_____	_____
_____	_____	_____	_____	_____	_____
_____	_____	_____	_____	_____	_____
_____	_____	_____	_____	_____	_____
_____	_____	_____	_____	_____	_____
Total	0	Total	0	Total	0

FALL	CR	SPRING	CR	SUMMER	CR
_____	_____	_____	_____	_____	_____
_____	_____	_____	_____	_____	_____
_____	_____	_____	_____	_____	_____
_____	_____	_____	_____	_____	_____
_____	_____	_____	_____	_____	_____
_____	_____	_____	_____	_____	_____
Total	0	Total	0	Total	0

FALL	CR	SPRING	CR	SUMMER	CR
_____	_____	_____	_____	_____	_____
_____	_____	_____	_____	_____	_____
_____	_____	_____	_____	_____	_____
_____	_____	_____	_____	_____	_____
_____	_____	_____	_____	_____	_____
_____	_____	_____	_____	_____	_____
Total	0	Total	0	Total	0

FALL	CR	SPRING	CR	SUMMER	CR
_____	_____	_____	_____	_____	_____
_____	_____	_____	_____	_____	_____
_____	_____	_____	_____	_____	_____
_____	_____	_____	_____	_____	_____
_____	_____	_____	_____	_____	_____
_____	_____	_____	_____	_____	_____
Total	0	Total	0	Total	0

ChE 392 is the 4-cr. Unit Ops lab held each June in Oviedo, Spain that subs for ChE325/426.

Notes:

SSH ELECTIVES

SINGLE DEPT. (6-9 Cr)

_____	Cr
_____	Cr
_____	Cr

OTHER SSH COURSES (6-9 Cr)

_____	Cr
_____	Cr
_____	Cr

Total 0 (15 Cr)

Which of the above SSH courses meet Intl & US Div.?

INT'L PERSPECTIVE (3 Cr)

_____	Cr
-------	----

US DIVERSITY (3 Cr)

_____	Cr
-------	----

TECH ELECTIVES (12.0 Cr total)

COMMUNICATION

ENGL 314	Cr
Total	0 (3 Cr)

ADVANCED CHEMISTRY

_____	Cr
_____	Cr
Total	0 (3 Cr)

STATISTICS

STAT 305	Cr
Total	0 (3 Cr)

CHEMICAL ENGINEERING

_____	Cr
_____	Cr
Total	0 (6 Cr)

ENGINEERING

_____	Cr
_____	Cr
Total	0 (3 Cr)

PROFESSIONAL

_____	Cr
_____	Cr
Total	0 (3 Cr)

Which resources did you utilize?

- CBE Handbook
- CBE website
- Schedule of Classes
- Course Catalog
- Degree Audit

Student Signature _____

Faculty Mentor Signature _____

CHEMICAL ENGINEERING FLOWCHART, 2020-2021 (129 CREDITS)

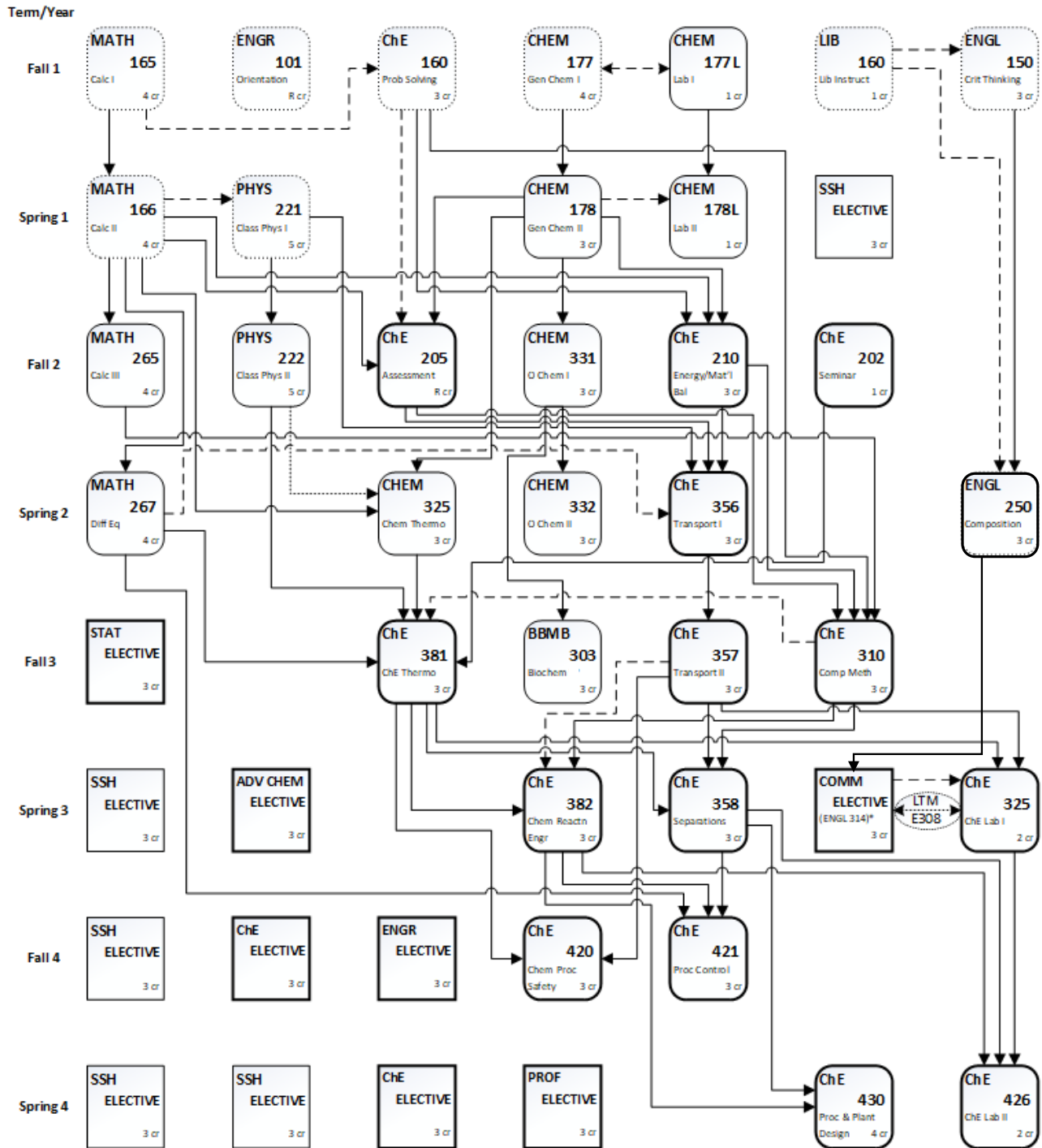

US DIV
 Int'l Persp
 6 - 9 cr SSH from same dept.



* LTM E 308 consists of taking specific sections of Engl 314 and ChE 325 together.

Undergraduate Curriculum in Chemical Engineering

2020-21 Catalog
Total Credits = 129

First Year (32)

Fall Semester (16)

4	+ MATH 165	Calculus I
3	+ ENGL 150	Crit. Think. & Comm.
4	+@CHEM 177	General Chemistry I
1	@CHEM 177L	General Chemistry I Lab
3	+ CH E 160	Chem. Engr. Problems
R	+ ENGR 101	Engineering Orientation
1	+ LIB 160	Information Literacy

Spring Semester (16)

4	+MATH 166	Calculus II
3	@CHEM 178	General Chemistry II
1	@CHEM 178L	General Chemistry II Lab
5	+PHYS 221	Intro. to Physics I
3		SSH Elective

Second Year (32)

Fall Semester (16)

3	* CH E 210	Material & Energy Bal.
4	MATH 265	Calculus III
5	PHYS 222	Intro. to Physics II
3	CHEM 331	Organic Chemistry I
1	* CH E 202	Seminar
R	CH E 205	Assessment

Spring Semester (16)

3	* CH E 356	Transport Phenomena I
4	MATH 267	Differential Equations
3	CHEM 332	Organic Chemistry II
3	CHEM 325	Chemical Thermodynamics
3	ENGL 250	Written/Oral/Vis/Elect. Comp.

Third Year (32)

Fall Semester (15)

3	* CH E 310	Computational Methods in ChE
3	* CH E 357	Transport Phenomena II
3	* CH E 381	ChE Thermodynamics
3	BBMB 303	Biochemistry
3		Statistics Elective

Spring Semester (17)

3		Communication Elective	} ☆
2	* CH E 325	ChE Laboratory I	
3	* CH E 358	Separations	
3	* CH E 382	Chemical Reaction Engr	
3		Chemistry Elective	
3		SSH Elective	

Fourth Year (33)

Fall Semester (15)

3	* CH E 421	Process Control
3	* CH E 420	Chemical Process Safety
3		Engineering Elective
3		ChE Elective
3		SSH Elective

Spring Semester (18)

4	* CH E 430	Process and Plant Design
2	* CH E 426	ChE Laboratory II
3		Professional Elective
3		ChE Elective
3		SSH Elective
3		SSH Elective

+ Basic Program - must earn a minimum 2.00 GPA. See the Basic Program for Engineering Curricula in the ISU Catalog.

(<http://catalog.iastate.edu/collegeofengineering/#basicprogramcurriculertext>)

* CH E Core – must earn a minimum 2.00 GPA

☆ LTM E308 consists of taking specific sections of ENGL 314 and CH E 325 together.

@ See the Chem 201/201L Policy (p. 22).

Electives

The chemical engineering curriculum provides considerable flexibility, which allows you to tailor the curriculum to meet your own needs. The elective requirements are in social sciences/humanities and in technical areas including communication.

You are ***strongly encouraged*** to take the LTM E308 learning community that integrates the writing component of ENGL 314 with the lab reports in CH E 325. This provides you with the advantage of extra help with your written reports and joint assignments that are submitted to both classes.

The chemical engineering curriculum includes 21 credits of technical electives, which provide students the opportunity to develop a deeper understanding of additional areas of science and engineering. You are encouraged to carefully plan your elective choices. Elective planning should be done in consultation with your faculty mentor and the choices must be clearly identified on your curriculum Plan of Study (POS).

Technical electives can be selected to develop a breadth of knowledge or to establish an “area of emphasis.” For example, you may wish to take a broad range of courses to prepare for graduate school. Alternatively, you may wish to focus your studies to develop a stronger background in an area of emphasis, such as biochemical engineering or food engineering. Suggestions for several additional areas of emphasis are listed on pages 19 - 20. Your faculty mentor also can assist you in preparing an emphasis not currently listed on those pages. Be sure to plan early enough to permit taking necessary prerequisites. **No more than six credits total of CH E 490 or other STEM departmental independent/research study may be counted toward technical electives.**

Table I – Electives

	MINIMUM CREDITS
Social Science & Humanities electives: (see pages 10-12)	15
Technical Electives	21
Communications electives: ENGL 309, ENGL 312, ENGL 314, or JL MC 347	3
Advanced Chemistry electives: AGRON 320; BBMB 405, 411, 420, 461 ; CE 420 or ENSCI 459; CHEM 211, 211L, 301, 316, 316L, 321L, 322L, 324, 326, 331L or 333L, 332L or 334L, 401L, 402; FS HN 311, 311L, 410	3**
Statistics electives: STAT 305, 231	3
Chemical Engineering electives: These include CH E 406, 408, 410, 415, 440, 447***, and any other 300+ CH E course not specified as required in the curriculum	6
Engineering electives: Any 300+ engineering course outside of chemical engineering that does not repeat material in required CH E courses and is not on SSH list. Approved exceptions: AER E 261, B M E 220, BRT 501, CPR E 281, EE 201, CE 274, and MAT E 273 Consult mentor for approval.	3
Professional electives: 300+ Physical Science, Life Science, Engineering, Statistics, Mathematics, or Computer Science not on SSH list Approved exceptions: MATH 207, MICRO 201, 201L, and those approved for Engineering & Advanced Chemistry electives.	3

* Courses not allowed as Technical Elective due to content overlap with required CH E courses: A B E 316; AER E 446; E M 378; FSHN 351, 442; MAT E 311, 391; M E 332, 335, 411, 421, 436, 475. I E 430 is only allowed as a Professional Elective, not as an Engineering Elective.

** See the Chem 201/201L Policy (p. 22).

*** Only one of CH E 447 or MAT E 351 may count toward graduation.

CH E Electives Availability

***as of this handbook's printing. Subject to change later - see CBE department page > Current Students > ChE Electives

Fall 2020 Semester

- **CH E 408: Surface and Colloid Chemistry** (pre-reqs: CH E 381)
- **CH E 410: Electrochemical Engineering** (pre-reqs: CH E 357, CH E 381, CH E 382)
- **CH E 440: Biomedical Applications of Chemical Engineering** (pre-reqs: CH E 210, Math 267)

Spring 2021 Semester

- **CH E 406: Environmental Chemodynamics** (pre-reqs: CH E 357, CH E 381)
- **CH E 415: Biochemical Engineering** (pre-reqs: CH E 357, Chem 331, BBMB 301/303/404)
- **CH E 447: Polymers and Polymer Engineering** (pre-reqs: Chem 331; CH E 382 or MAT E 351)

Fall 2021 Semester

- **CH E 408: Surface and Colloid Chemistry** (pre-reqs: CH E 381)
- **CH E 410: Electrochemical Engineering** (pre-reqs: CH E 357, CH E 381, CH E 382)
- **CH E 440: Biomedical Applications of Chemical Engineering** (pre-reqs: CH E 210, Math 267)

Spring 2022 Semester

- **CH E 406: Environmental Chemodynamics** (pre-reqs: CH E 357, CH E 381)
- **CH E 415: Biochemical Engineering** (pre-reqs: CH E 357, Chem 331, BBMB 301/303/404)
- **CH E 447: Polymers and Polymer Engineering** (pre-reqs: Chem 331; CH E 382 or MAT E 351)

Fall 2022 Semester

- **CH E 408: Surface and Colloid Chemistry** (pre-reqs: CH E 381)
- **CH E 410: Electrochemical Engineering** (pre-reqs: CH E 357, CH E 381, CH E 382)
- **CH E 440: Biomedical Applications of Chemical Engineering** (pre-reqs: CH E 210, Math 267)

Spring 2023 Semester

- **CH E 406: Environmental Chemodynamics** (pre-reqs: CH E 357, CH E 381)
- **CH E 415: Biochemical Engineering** (pre-reqs: CH E 357, Chem 331, BBMB 301/303/404)
- **CH E 447: Polymers and Polymer Engineering** (pre-reqs: Chem 331; CH E 382 or MAT E 351)

Suggested Emphases for Technical Electives

Listed below are courses that you may consider taking as part of your group of electives for a desired career path. These lists are not exhaustive, and sometimes more courses are suggested than a student has time to take. You should work closely with your faculty mentor to choose an appropriate set of electives to suit your individual career goals.

Note: Make sure to consult the University Catalog for the required prerequisites and co-requisites.

General Graduate School Preparation

Advanced Chemistry Electives

CHEM 324 (3) Introductory Quantum Mechanics

CH E Electives

CH E 408 (3) Surface and Colloid Chemistry

CH E 415 (3) Biochemical Engineering

CH E 447 (3) Polymers and Polymer Engineering

CH E 490 (variable) Research/Independent Study

CH E 545 (3) Analytical and Numerical Methods

CH E 500-level courses

Engineering Electives

EE 201 (4) Electric Circuits

CE 274 (3) Statics of Engineering

Professional Electives

MATH 207 (3) Matrices and Linear Algebra

MATH 385 (3) Introduction to Partial Differential Equations

General Industrial Preparation

Advanced Chemistry Electives

CHEM 211/211L (2/2) Quantitative and Environmental Analysis/Lab

CHEM 301 (2) Inorganic Chemistry

CH E Electives

CH E 406 (3) Environmental Chemodynamics

CH E 408 (3) Surface and Colloid Chemistry

CH E 410 (3) Electrochemical Engineering

CH E 415 (3) Biochemical Engineering

CH E 447 (3) Polymers and Polymer Engineering

Engineering Electives

IE 305 (3) Engineering Economic Analysis

CE 274 (3) Statics of Engineering

Biochemical Engineering

Advanced Chemistry Electives

BBMB 405 (3) Biochemistry II

BBMB 420 (3) Mammalian Biochemistry

CH E Electives

CH E 415 (3) Biochemical Engineering

Engineering Electives

C E 421 (3) Environmental Biotechnology

Professional Electives

MICRO 201 (2) General Microbiology

BRT 501 (3) Fundamentals of Biorenewable Resources

Biomedical Engineering

Advanced Chemistry Electives

- BBMB 405 (3) Biochemistry II
- BBMB 420 (3) Mammalian Biochemistry

CH E Electives

- CH E 415 (3) Biochemical Engineering
- CH E 440 (3) Biomedical Applications of Chemical Engineering

Engineering Electives

- EE 201 (4) Electric Circuits
- B M E 220 (3) Introduction to Biomedical Engineering
- B M E 341 (3) BioMEMs and Nanotechnology
- B M E 352 (3) Molecular, Cellular, and Tissue Biomechanics
- B M E 450 (3) Biosensing

Professional Electives

- BIOL 313 (3) Principles of Genetics
- BIOL 314 (3) Principles of Molecular Cell Biology

Environmental Science and Engineering

Advanced Chemistry Electives

- CE 420 (3) Environmental Engineering Chemistry

CH E Electives

- CH E 406 (3) Environmental Chemodynamics
- CH E 408 (3) Surface and Colloid Chemistry

Engineering Electives

- C E 326 (3) Principles of Environmental Engineering
- C E 421 (3) Environmental Biotechnology
- C E 428 (3) Water and Wastewater Treatment Plant Design
- C E 528 (3) Solid and Hazardous Waste Management

Professional Electives

- ENSCI 324 (3) Energy and the Environment

Food Engineering

Advanced Chemistry Electives

- FS HN 311 (3) Food Chemistry

CH E Electives

- CH E 408 (3) Surface and Colloid Chemistry
- CH E 415 (3) Biochemical Engineering

Engineering Electives

- A B E 451 (3) Food and Bioprocess Engineering

Professional Electives

- FS HN 412 (4) Food Product Development
- FS HN 420 (3) Food Microbiology
- FS HN 421 (3) Food Microbiology Laboratory
- FS HN 471 (3) Food Processing I
- FS HN 472 (3) Food Processing II

Materials Science

Advanced Chemistry Electives

- CHEM 301 (2) Inorganic Chemistry - non-metals

CH E Electives

- CH E 440 (3) Biomedical Applications of Chemical Engineering
- CH E 447 (3) Polymers and Polymer Engineering

Engineering Electives

- MAT E 273 (3) Principles of Materials Science and Engineering
- MAT E 454 (3) Polymer Composites and Processing

Professional Electives

- PHYS 321 (3) Introduction to Modern Physics I

Biomedical Engineering Minor

The Biomedical Engineering Minor is open to all undergraduate engineering students at Iowa State University. This minor will provide students with a foundation of core biology and engineering concepts relevant to further study in biomedical engineering. In addition, students will receive an introduction to the application of engineering principles to biomedical problems from a multidisciplinary perspective as well as the applications within the majors of the participating departments. See the Biomedical Engineering Minor Program webpage for complete details:

<https://www.engineering.iastate.edu/bioengineering/>

<https://www.engineering.iastate.edu/bioengineering/minor-requirements/>

Policies

Transfer Credits

1. By departmental policy, only transfer grades of “C” and higher are accepted for curriculum requirements.
2. A maximum of 65 credits from a 2-year school can be applied to degree requirements.
3. The last 32 credits of the degree program must be earned at Iowa State University. Exceptions may be granted in special cases. Speak with your adviser for more information.
4. Transfer students with transfer credits in chemical engineering core courses must earn at least 15 semester credits in Iowa State University courses in this category at the 300-level or above to qualify for the B.S. degree in chemical engineering.

Academic Warning or Probation

If you are on Academic Warning or Probation based upon the grades you earned in the fall or spring semester, you must complete an Academic Intervention Self-Assessment as soon as possible (available on AccessPlus). Once this is complete, you must meet with your academic adviser no later than the 10th class day of the subsequent semester to discuss the obstacles that have impacted your academic success. A registration hold for the next semester will be placed on your account until you meet with your adviser.

English Proficiency Requirement

Beyond the completion of the freshman composition courses, ENGL 150 and ENGL 250, certification of English proficiency is the responsibility of the student’s major department. In chemical engineering, certification is accomplished by successful completion of the communication elective (ENGL 309, ENGL 312, ENGL 314, or JL MC 347).

Students whose first language is not English must pass an English proficiency examination before taking ENGL 150. A student not passing the exam must enroll each semester in a special English program until the minimum standards are met. This English program is designed to improve English skills resulting in increased success in coursework.

CHEM 201/201L Policy

Students can fulfill the general chemistry requirement (CHEM 177, 177L, 178, and 178L) with CHEM 201 and 201L. However, they must take another 3 credits of advanced chemistry electives above the 3 credits required of all students. This is necessary to eliminate the three-credit chemistry deficiency caused by the difference in credits between the CHEM 177, 177L, 178, and 178L sequence (9 credits) and the CHEM 201 and 201L sequence (6 credits). This applies to all students taking CHEM 201, including those that have transfer credit, dual enrollment credit, international baccalaureate credit, or advanced placement credit for CHEM 178. CHEM 178 credit cannot be combined with CHEM 201 and CHEM 201L. However, students may elect to use transfer credit for CHEM 177, 177L, 178, and 178L, even if they have taken CHEM 201 and 201L.

Graduation Requirements

You are able to obtain a copy of your Degree Audit at any time in AccessPlus. You should check each semester to ensure that each course taken or transferred is properly applied to the correct curricular category. Ask your academic adviser to make any necessary corrections to your Degree Audit to ensure everything is correct by the semester preceding your expected term of graduation. Students will need to fill out an Application for Graduation (available on AccessPlus) at the same time as registering for the term they plan to graduate. The applications will be accepted during the registration period for the graduation term.

See the following webpage for more information: <https://www.graduation.iastate.edu/>

Pass-Not Pass Policy

Students may choose to take a maximum of 9 semester credit hours on a Pass-Not Pass (P/NP) basis. Only SSH elective courses that are not being used to satisfy the US Diversity or International Perspective requirements and other courses that are not applying towards graduation may be taken as P/NP. Consult your adviser before attempting to take a course as P/NP.

Prerequisites and Co-requisites

Prerequisites and co-requisites for chemical engineering courses must be followed as they are listed in a student's catalog year. If a student does not meet the necessary prerequisites or co-requisites for a chemical engineering course, then they must complete a "Request to Waive a Prerequisite/Co-requisite" form. This form can be found on the CBE website: <https://www.cbe.iastate.edu/files/2018/08/CBE-Prereq-Waiver-Form-New-Aug-2018.pdf>

A student who wishes to drop a co-requisite course must also drop the corresponding CH E course. Failure to drop the corresponding CH E course will result in a grade of F for this course. This policy applies to the courses shown in the table below.

Co-Requisite Course (if dropping this)	CH E Course (must also drop this)
MATH 165	CH E 160
CH E 160	CH E 205
Communication Elective	CH E 325
MATH 267	CH E 356
CH E 310	CH E 381
CH E 357	CH E 382

The Iowa State University Catalog lists the prerequisites and co-requisites for every course. For some of the technical electives listed on pages 17 and 19-20, prerequisites and co-requisites may apply only to students in that specific area of study. Prerequisites may be waived by the course instructor if the course is being taken by someone outside of that department's curriculum. *Always consult with your course instructor about waiving any prerequisites for your technical electives.*

Part 3: Opportunities for Undergraduates

International Studies in Chemical and Biological Engineering

There are numerous international programs and experiences available to chemical engineering students. Through these programs you have the opportunity to:

- ❖ Study for 1-2 semesters at prominent chemical engineering departments in Europe, Asia, or Australia
- ❖ Participate in a 5-week summer school course in Oviedo, Spain
- ❖ Gain international work experience with a global corporation in conjunction with an academic exchange

Iowa State University has several points of contact when it comes to international programs and experiences. Both Engineering International Programs and Iowa State's Study Abroad Center are great resources for students who are considering an international experience. Visit with these departments' websites or go in person to get the most up-to-date information about programs you are interested in.

- ❖ Engineering International Programs: <http://www.engineering.iastate.edu/studyabroad/>
- ❖ Study Abroad Center: <http://www.studyabroad.iastate.edu/>

University of Oviedo Summer Laboratory Program

The CBE department has a summer study program in Oviedo, Spain, available to juniors, seniors, and qualified sophomores involving a chemical engineering laboratory course. This 5-week program offers the opportunity to complete a lecture and laboratory course at the University of Oviedo and to compare the technical and cultural aspects of the U.S. and Spain. Ample opportunities to travel in Europe are available for those deciding to do so. Students from University of Wisconsin-Madison also participate in the Oviedo program.

Iowa State students who participate in this program earn seven semester credits in CH E 391 and CH E 392, which apply toward the B.S. requirements (four credits substitute for CH E 325 and CH E 426 and three credits may apply to the SSH requirement). The credits are given on the basis of participating in the following:

- ❖ An orientation course (CH E 391) during spring semester at Iowa State;
- ❖ Lectures attended and laboratory experiments performed during a five-week program at the University of Oviedo;
- ❖ Visits to Spanish chemical engineering departments, research laboratories, and manufacturing facilities, mostly during the third week of the program.

For application deadlines, cost information, or any other question about the program, please contact Dr. Stephanie Loveland: 2052 Sweeney Hall; 515-294-3024.

International University Exchanges

The CBE department administers several university exchanges with international universities. The mutual exchange agreements involve several of the leading chemical engineering departments in Europe, Australia, and Asia. Students generally attend for one to two semesters, perhaps with a travel period coordinated with the university schedules. Coursework is sufficiently similar at these universities so that students are able to continue their degree program at Iowa State without interruption.

The programs are organized according to Iowa State procedures established through the Iowa State University Study Abroad Center. This includes:

- ❖ Applying for the program at specific dates (see each program below)
- ❖ Registering and paying tuition and fees as if remaining at ISU, but selecting course work at the international university
- ❖ Paying no fees at the international university, but providing your own transportation and living costs
- ❖ Receiving credit for the courses towards your degree

Specific arrangements for each program differ slightly; contact the program coordinator for each exchange.

Visit the Engineering International Programs website, <http://www.engineering.iastate.edu/studyabroad>, or email eip@iastate.edu for general questions about study abroad and the application process. Below is a list of institutions where ISU chemical engineering students have studied at previously.

- ❖ National University of Singapore
- ❖ University College London — England
- ❖ University of Limerick — Ireland
- ❖ University of Newcastle – Australia
- ❖ Swansea University – Wales
- ❖ University of Canterbury – New Zealand

Honors Program

Students with high ability and clear educational objectives are encouraged to investigate the opportunities offered by the University Honors Program. The Honors Program emphasizes the development of individualized programs of study to meet the needs of students who have demonstrated the ability and maturity to assume more than the usual degree of responsibility for their education. The Honors Program also offers the opportunity to take Honors courses and Honors seminars, to make arrangements to take almost any course for Honors credit, and to carry out individual projects of an original, scholarly nature. Graduation as a member of the Honors Program is noted on the student's diploma, permanent record, and in the commencement program.

An undergraduate student who has a cumulative grade point average of 3.50 or greater may apply for the program during the second semester of residence or thereafter. A student must participate for a minimum of 48 credit hours. Students with lower grade point averages may be admitted providing they appear to have unusual potential or have demonstrated outstanding scholastic ability in other ways. Transfer students also have the opportunity to join the Honors Program provided they meet the necessary requirements.

More information about the program can be obtained from
Dr. Eric Cochran, 3133 Sweeney Hall; Dr. Kurt Hebert, 3155 Sweeney Hall;
Dr. R. Dennis Vigil, 3037 Sweeney Hall; Dr. Surya Mallapragada, 2031 Sweeney Hall or 2810 Beardshear; or
Dr. Brent Shanks, 1140L Biorenewables Lab
who all serve as mentors to chemical engineering students in the Honors program.

Information can also be obtained from the Honors Program Office in the Jischke Honors Building
or via the Honors website: <http://www.honors.iastate.edu/>.

Undergraduate Research Program and Independent Study

Students may participate in a special undergraduate research program or may pursue independent study through CH E 490. These opportunities may be particularly valuable for students planning to obtain an advanced degree or for students desiring work in a specific industry.

Examples of CH E 490 projects include:

- Literature studies/reviews
- Completion of the American Institute of Chemical Engineers Student Design Contest Problem
- Setting up a laboratory experiment

Students select these projects by consulting with individual faculty members, who then serve as the project supervisor. Election of course and topic must be approved in advance by project supervisor and Curriculum Committee Chair with the completion of a CH E 490 Study Proposal form available for download at <http://www.cbe.iastate.edu/current-students/forms>. Upon completion of the project, students must submit a final report or give a presentation to their faculty coordinator. Participation in regional student AIChE chapter meetings is also anticipated for outstanding contributions. **No more than six credits total of CH E 490 or other departmental independent/research study may be counted towards technical electives.**

Honors Program students may participate by registering for CH E 490H and completing an Honors Project Approval Form, which is available for download at <https://www.engineering.iastate.edu/engrhonors/honors-project/>.

American Institute of Chemical Engineers (AIChE)

The professional society for chemical engineering is the American Institute of Chemical Engineers (AIChE). Iowa State University has a very active student chapter, which has gained national recognition through recent awards for its program and leadership and awards won in student paper contests at regional meetings. More than one third of the undergraduates in chemical engineering are members of the student chapter.

The objectives of the chapter are to promote the professional development of its members and to contribute to the development of chemical engineering at Iowa State. Membership provides the opportunity to meet other chemical engineering students and the members of the faculty, to learn about the professional experiences of others, and to discuss employment and career possibilities.

Meetings will normally be held in the evening in Sweeney Hall. Event information is made available through a member email list and the ISU AIChE Facebook group. Other activities include attending the regional AIChE conference and participating on the Chem-E-Car team. Club officers present an update to the department at the CBE Awards Banquet.

The best time to sign up for membership is at the AIChE fall picnic. Membership dues are collected each semester. If you have any questions about the student chapter, feel free to contact any of the officers listed on the AIChE website. We are looking forward to seeing you at the meetings.

Chapter website: <http://aiche.cbe.iastate.edu>

National Organization for the Professional Advancement of Black Chemists and Chemical Engineers (NOBCChE)

NOBCChE offers diverse programs designed to foster professional development and encourage students to pursue careers in science and technical fields. Also, the club provides industrial chemical companies with an avenue for better selection of prospective applicants.

Adviser: Derrick Rollins – CH E

Omega Chi Epsilon

Omega Chi Epsilon, Chemical Engineering Honor Society, recognizes and promotes high scholarship, original investigation, and professional service in chemical engineering. The honor society was formed at the University of Illinois in 1931. The Beta Chapter was formed at Iowa State in 1932 and went inactive in 1937. The local chapter was reactivated in 1966. The current national membership includes more than 20,000 men and women from 67 chapters.

To be considered for membership, juniors must have a minimum 3.25 GPA and seniors a minimum 3.00 GPA. Eligible students also must have completed six credits of chemical engineering courses. In addition, members must possess traits of personality and leadership that make them most likely to succeed in their chosen fields. Initiation ceremonies are held during fall semester. The chapter organizes a number of service activities throughout the year, including: hosting student-faculty Friday After Classes (FACs), hosting the department's spring picnic, providing student representatives for departmental committees, and sponsoring the Omega Chi Epsilon Outstanding Senior Award given at the CBE department banquet.

Adviser: Zengyi Shao

Chapter Website: <http://www.engineering.iastate.edu/oxe/>

Other Honor Societies

There are a number of other honor societies available to chemical engineering students in addition to Omega Chi Epsilon. Some of them are listed below. Unless otherwise stated, membership is university-wide and available to undergraduates.

Society	Restrictions	Qualities Recognized
Alpha Lambda Delta	Freshmen	Scholarship
Cardinal Key	Seniors	Leadership, service, scholarship
Mortar Board	Juniors	Scholarship, leadership, service
Phi Eta Sigma	Freshmen	Scholarship
Phi Kappa Phi	All-University	Scholarship
Tau Beta Pi	Engineering College	Scholarship, character

Employment and Scholarship Opportunities

Each year the College of Engineering, through its Scholarships and Awards Committee, offers awards to engineering students. Various companies, trade associations, and individuals donate these awards. More information is available online at <http://www.engineering.iastate.edu/student-services/scholarships>. These awards are based primarily on academic performance and university involvement. The Office of Student Financial Aid, 0210 Beardshear Hall or <http://www.financialaid.iastate.edu>, handles scholarships based on financial need.

To be considered for a College of Engineering Scholarship, the applicant must have attended Iowa State University for a period of one semester prior to spring semester and must have at least two semesters remaining in which to use the award starting in the fall semester. The number of scholarships available for freshmen is limited, so the majority of the awards are made for use during the student's junior or senior years. **Applications must be submitted online and are normally due by February 1.**

For additional information, contact Jane Stowe at 294-9295/jmstowe@iastate.edu or engineeringscholarships@iastate.edu

Employment opportunities for students include, but are not limited to the following:

- Undergraduate Research Assistants
- CBE Student Assistants
- Peer Mentors

For additional information visit https://iastate.qualtrics.com/jfe/form/SV_4Jc8cxJeMTE31hr

Co-ops and Internships

Co-op and internship experiences provide an opportunity for students enrolled in chemical engineering to gain practical experience while working toward their B.S. degrees. Such work arrangements are with companies located throughout the U.S., but the majority are in Iowa and Minnesota. The College of Engineering hosts a career fair during both the fall and spring semesters so that students can meet with representatives from companies and agencies that offer co-ops and internships. Engineering Career Services maintains an up-to-date listing of co-op, internship and full-time job opportunities, easily accessible in the CyHire app.

Eligible Iowa State engineering students who accept co-op or internship positions can register these experiences so that they show up on the student's transcript. Deadlines, eligibility requirements, and registration instructions are located on the Engineering Career Services webpage: <http://www.engineering.iastate.edu/ecs/internships/how-to-register/>.

Advantages of the program are that students:

- ❖ Increase competitive edge for full-time employment
- ❖ Enhance career exploration and clarification of professional goals
- ❖ Develop greater responsibility and self-confidence
- ❖ Improve interpersonal and communication skills
- ❖ Create a process of development, assessment, and continuous professional growth
- ❖ Maintain full-time student status without tuition and fees
- ❖ Reflect work experience on transcript
- ❖ Earn money to help cover their college expenses
- ❖ Complement classroom learning with practical work experience

Disadvantages include:

- ❖ Loss of continuity in some course sequences because of the periodic interruption of work
- ❖ Possible limitations in participating in some outside activities
- ❖ Lengthening of program

For additional information, speak with your adviser or contact Engineering Career Services <http://www.engineering.iastate.edu/ecs>; 515 294-2540.